

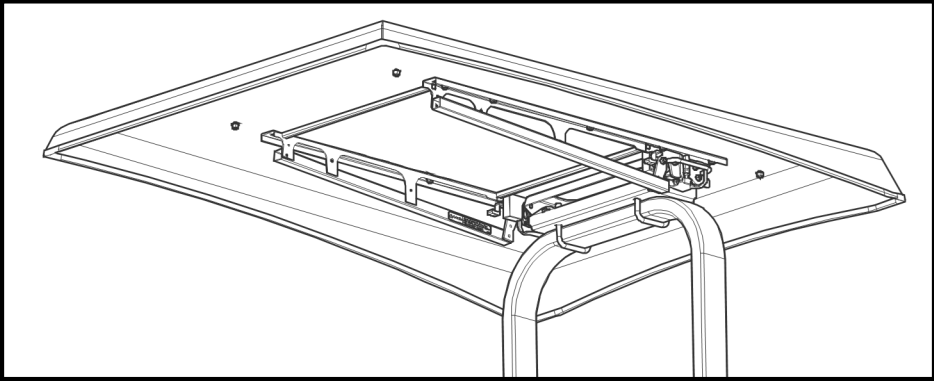

# Universal Tractor Canopy

p/n: 1UTCX (Standard) or 1UTCLX (Large)  
 1UTCWRX (Std Wide ROPS) or 1UTCLWRX (Large Wide ROPS)  
 (X represents a 1, 2, or 3 character suffix code regarding paint color)  
 (examples: 1UTC0, 1UTC0W, etc.)  
 O = Orange, OW = White, TB = Black,  
 JG = Green, CG = Gray, MHR = Red  
 NB = New Holland Blue



**ATTENTION:**  
 It is critical to adjust the rubber bumpers on the latching frame to ensure minimal vibration in the canopy during tractor operation. Please follow the instructions in Step 5 carefully. Failure to do so may result in damage to the canopy.

**CAUTION**

- To prevent damage to Canopy:
1. Remove before trailering at speeds over 35 MPH.
  2. Do not allow more than 12 inches of snow to accumulate on top.
  3. Do not use as grab handle to get on and off of vehicle.

**NOTE:** Park vehicle on level ground.

1. See service parts page for names of items. Remove the sub-assembly of the ROPS plate and striker plate from the latching frame by unlatching and lifting out. Per fig. 1, separate the ROPS plate from the striker plate by removing and discarding one screw from each side of the sub-assembly.

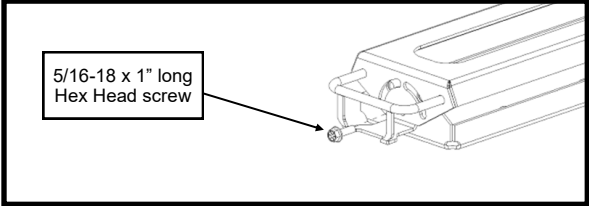

Fig. 1 (Remove 2 bolts)

- Tools Required**  
 1/2" wrench or socket
2. Per fig. 2, position the ROPS plate on top of the vehicle ROPS, with the very long arched slots for the U-bolts to the rear of the tractor. If the threads of the U-bolts do not stick down through the ROPS plate, install 4 of the 16 supplied 1/2" washers over each leg of the U-bolts. Install nuts onto the U-bolts. Adjust the position of the ROPS plate so U-bolts are in contact with the front face of the vehicle ROPS (to ensure it is parallel with the ROPS). If required, rotate the U-bolts in the rear slots so they are tight to the back of the ROPS. Center the ROPS plate left to right and tighten the nuts to 22 ft.-lbs.

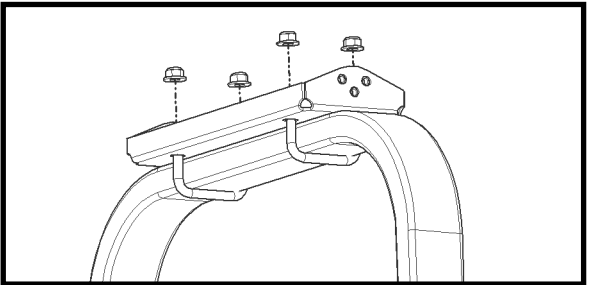

Fig. 2 (Attach ROPS Plate)

**Tools Required**  
 3/4" wrench or socket

**Hardware Used**

	<u>Qty</u>
U-Bolt, 3.13 x 3.5", 1/2-13 Thread	4
1/2-13 Flanged Lock Nut	4
1/2" SAE Flat Washer	up to 16

# Canopy Installation

3. Per fig. 3, attach the Striker Plate to the ROPS Plate using the supplied 1" long 5/16-18 screws. Take care not to cross thread the weld nuts.

Use a level to set desired plate angle, then tighten screws. Tighten to 29 ft.-lbs.

**CAUTION:** Tightening the bolts may cause the attachment plate to twist. Make sure both sides are even and level before fully tightening.

### Tools Required

1/2" wrench or socket

Level

### Hardware Used

5/16-18 x 1" Flanged Hex Bolt

Qty

6

4. See figures 4a and b. Engage the latching frame into the striker plate. Position the canopy on top of the frame. The frame has multiple slots in it to allow the canopy to move front to back a total of 12".

For reference:

- For forward leaning ROPS, use rearward holes.
- For vertical ROPS, use center holes.
- For rearward leaning ROPS, use forward holes.

Line up the holes in the canopy with the slots in the latching frame in the position that best suits your application. Note and/or mark the position and remove the canopy and frame from the tractor. Attach canopy to frame using supplied hardware, 3/4" long 5/16-18 screws through steel washer, rubber washer, then canopy. Tighten hardware to 120 inch-lbs.

### Tools Required

Two 1/2" wrenches or sockets

### Hardware Used

5/16-18 x 3/4" Flanged Hex Bolt

Qty

14

5/16" x 1-1/4" Steel Fender Washer

14

5/16" x 1-1/4" Rubber Fender Washer

14

5/16-18 Flanged Lock Nut

14

**NOTE:** Install hardware in every hole in the canopy regardless of whether or not it goes through the frame. This will ensure the canopy is water tight.

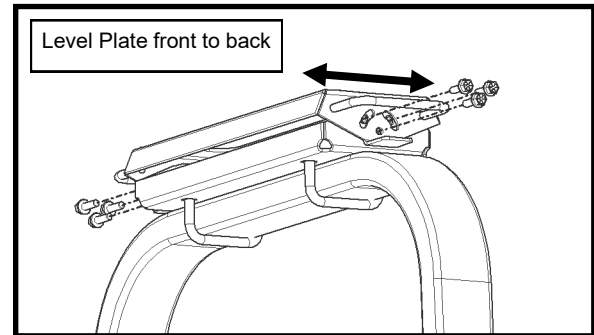

Fig. 3 (Attach Striker Plate)

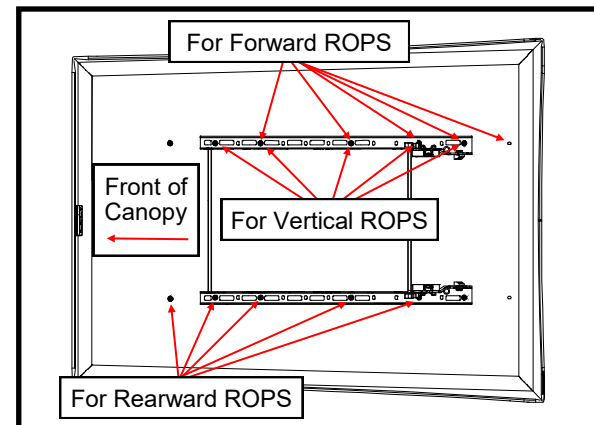

Fig. 4a (Hole Alignment)

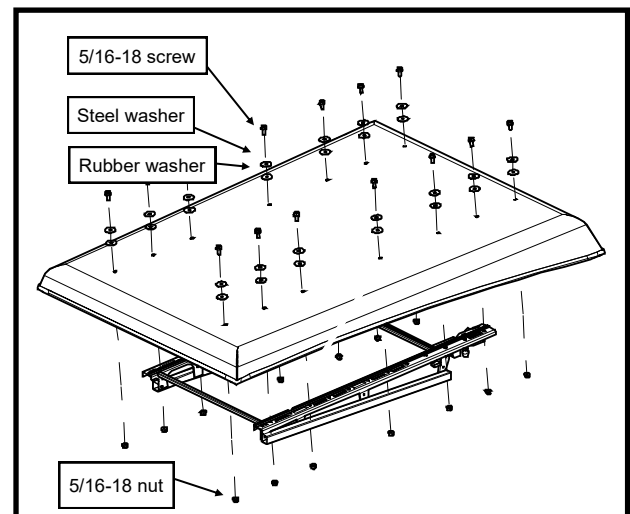

Fig. 4b (Attach Canopy to Frame)

## Canopy Installation

5. Loosen the jam nut on each bumper (see figure 5a), then mount and latch the canopy per fig. 5b. With one hand, push upwards on the canopy to take up the play in the latches. With the other hand, unthread both bumpers down finger tight to the striker plate. Unlatch and pivot the canopy up to further unthread each bumper equally one full turn at a time. Re-latch and check latching resistance after each adjustment. The bumpers should stabilize the canopy and it should require downward force to latch, but not so much that double clicking the latches becomes difficult. Unlatch a final time and tighten the jam nut on each bumper to 10 ft-lbs.

### **Tools Required**

Two 1/2" wrenches or crowfoot sockets

6. Discard any extra washers.

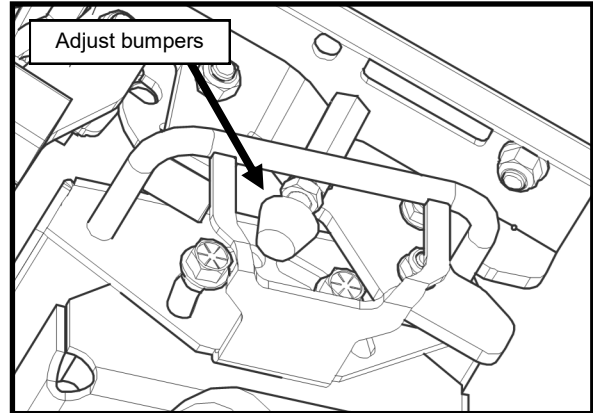

Fig. 5a (Adjust Bumpers)

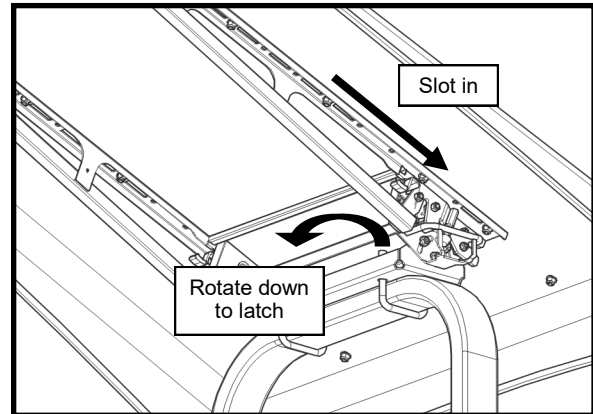
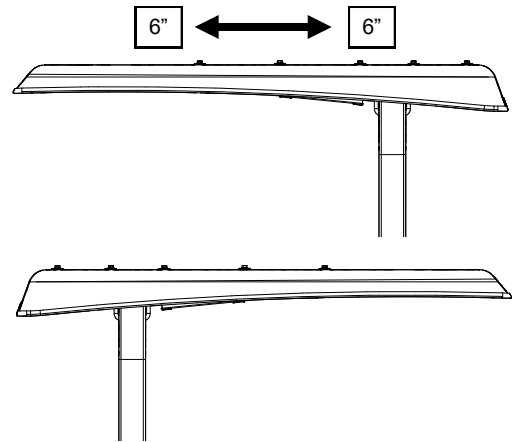

Fig. 5b (Latch Canopy)

# Canopy Features and Service Parts

## ADJUSTABLE FRONT TO BACK ±6"

For proper sun or rain coverage, the canopy can be adjusted front to back in 3" increments up to 6" in either direction. To adjust, unbolt the canopy from the Latching Frame, move it to a different set of mounting slots, and bolt it back together.



## TOOL-LESS REVERSIBILITY

The canopy can be reversed in seconds without tools if shade or rain protection is desired when using a backhoe.

To reverse:

- 1) Unlatch canopy as if it would be removed normally.
- 2) Re-latch canopy in the reversed position.

CANOPY, ALUMINUM, UTC  
42" x 55"

- P/N: 101-00035-TB (texture black)
- P/N: 101-00035-JG (John Deere green)
- P/N: 101-00035-O (Kubota orange)
- P/N: 101-00035-CG (gray)
- P/N: 101-00035-MHR (Mahindra red)
- P/N: 101-00035-OW (Oxford white)
- P/N: 101-00035-NB (New Holland blue)

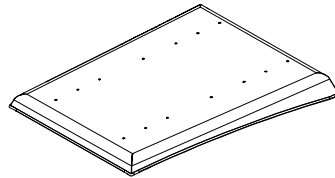

ROPS PLATE & STRIKER PLATE WIDE ROPS  
P/N: 8SV-WA-00857

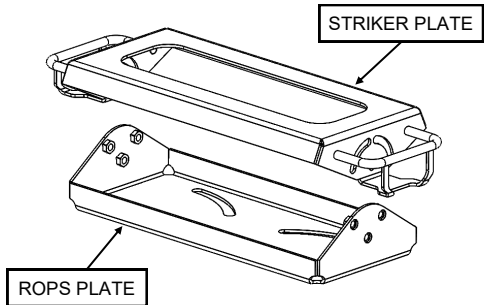

CANOPY, LARGE, ALUMINUM, UTC  
49" x 63"

- P/N: 101-00063-TB (texture black)
- P/N: 101-00063-JG (John Deere green)
- P/N: 101-00063-O (Kubota orange)
- P/N: 101-00063-CG (charcoal gray)
- P/N: 101-00063-MHR (Mahindra red)
- P/N: 101-00063-OW (Oxford white)
- P/N: 101-00063-NB (New Holland blue)

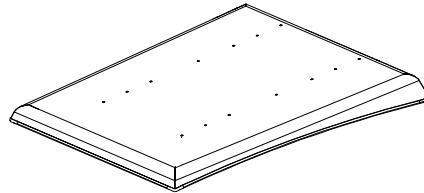

ROPS PLATE & STRIKER PLATE  
P/N: 8SV-WA-00590

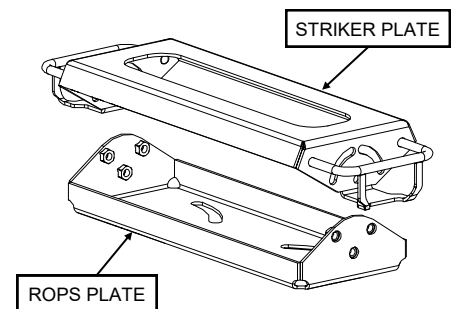

LATCHING FRAME  
P/N: 8SV-WA-00534

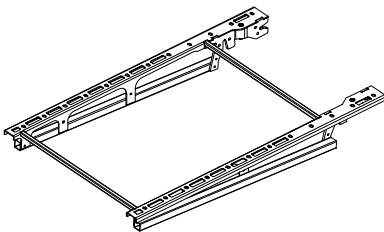

BUMPERS (2)  
P/N: 9SV-79-89-0044

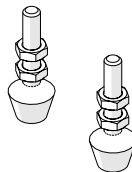

ALIGNMENT BLOCK  
P/N: 9SV-P-00088

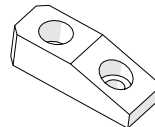

LATCHES, 1L&1R, W/ COVERS & FASTENERS  
P/N: 9SV-9DL06SC

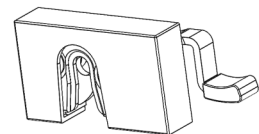

PART NUMBER	DESCRIPTION
9SV-HWK-00093	HARDWARE KIT, UNIVERSAL TRACTOR CANOPY
9SV-HWK-00227	HARDWARE KIT, UNIVERSAL TRACTOR CANOPY WIDE ROPS
9SV-HWK-00138	HARDWARE KIT, LATCH (4 FLATHEAD BOLTS AND 4 LOCKNUTS)

# Canopy Service Parts

LATCH FRAME ASSEMBLY, WITHOUT MOUNTS  
P/N: 113-00428

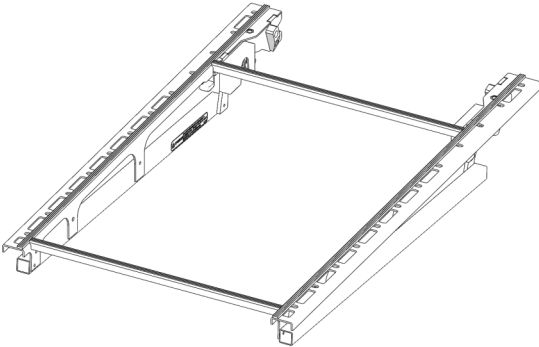

MOUNT KIT  
P/N: 113-00179

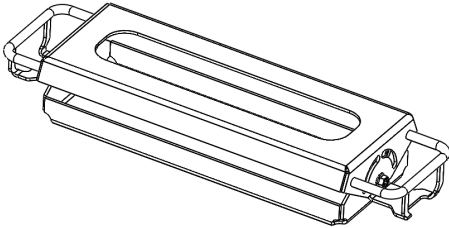

---

MOUNT KIT WIDE ROPS  
P/N: 113-00483

