

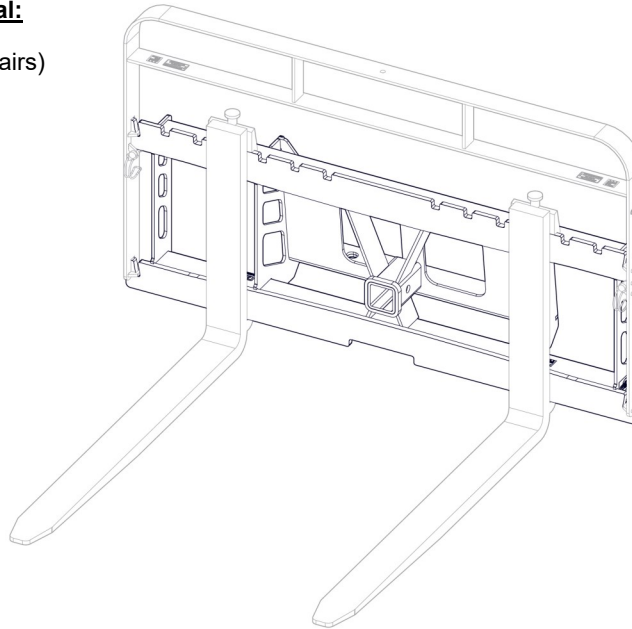

**ARTILLIAN PALLET FORK FRAME
FOR MINI SKID STEER
P/N: FF-30-MSSHR
Fits Vehicles with: Common Industry Interface (CII)**

Shown with Optional:

Fork Tines (Sold in pairs)
Backrest (P/N 5-BR)



Available Attachments:

- HYDRAULIC FITTING KIT, 1/2" FLAT FACE QUICK DISCONNECT (P/N HDK-FFQD-500)
- 3-POINT CAT/ASAE QUICK HITCH ADAPTER (P/N: 5-QHA)
- 60" ARTILLIAN HYDRAULIC PLOW (P/N: SPA-60HYD)
- 72" ARTILLIAN HYDRAULIC PLOW (P/N: SPA-72HYD)
- BACKREST, REMOVABLE, PALLET FORK FRAMES (P/N 5-BR)
- FRONTHOE BUCKET (P/N 5-FPS-916)
- GRAPPLE (P/N GRP-GP20-GR)
- RAKE (P/N GRP-GP20-RK)
- FORK TINE PAIR (5 DIFFERENT SIZE OPTIONS)
- HYDRAULIC SPLITTER MANIFOLD DOUBLE PORT (P/N HSM-SPM4P-F)
- HYDRAULIC SPLITTER MANIFOLD TRIPLE PORT (P/N HSM-SPM6P-F)
- HYDRAULIC HOSE ASSY, VALVE TO MANIFOLD, 30" LG (P/N HHA-HSM-30)
- BALL HITCH, 2 INCH (P/N: 1BH2IN)

Approximate Installation Time
Experienced Dealer Technician – 5 Minutes
Average Dealer Technician – 10 Minutes
Do-It-Yourself – 15 Minutes

Approximate Product Specifications
Pallet Fork Frame Width: 47-1/4 inches
Weight: 103 lbs. (not including accessories)
Capacity (MAX): 3000 pounds



CAUTION

Do not exceed the rated capacity for the Fork Frame or its attachments. Doing so may result in damage to the Fork Frame and will void the warranty.

The contents of this envelope are the property of the owner. Leave with the owner when installation is complete.

All images shown are for illustration purposes only. Actual product may vary due to product enhancement.

WARNINGS, TIPS, & REQUIRED TOOLS

Artillian products feature an assembly of parts designed for your vehicle which require adjustment and alignment of components to accommodate vehicle variations and provide proper installation. For accurate installation, proper operation, and years of satisfaction, please read and understand the installation and owner's manual fully prior to installing the product.

From all of us at Artillian, we thank you for choosing our product.

NOTICE

This product adds additional weight to the base vehicle. All product and accessory weights are listed in the Installation & Owner's Manual. Deduct the product (and accessories) total weight from the vehicle's rated capacity and never exceed the vehicle's rated capacity, including driver and passenger.



WARNING

SAFETY

1. **Wear gloves** whenever handling Artillian Pallet Forks and its attachments. Watch for sharp edges and possible pinching hazards. Steel toe boots, eye and hearing protection are also recommended anytime working around a tractor.
2. **It is the responsibility of the operator to provide adequate rear ballast** on the machine to counterbalance loads lifted with the pallet forks. Please reference your machine's owner's manual for proper ballasting methods.
3. **Front end loaders are optimized for speed and power, not necessarily for precise control. Heavy loads can drop very quickly. Make control inputs carefully. TAKE YOUR TIME. PLAN AHEAD. WATCH FOR OBJECTS ABOVE, BESIDE, BELOW, IN FRONT OF AND BEHIND YOU.**
4. Do not apply side forces to the fork tines as damage to the frame and/or forks may occur. If side forces have been applied, do not use the system until a complete inspection has been performed.
5. Be aware, when moving in reverse, of objects in your path while turning. If an object is struck, do not use the system until a complete inspection has been performed.
6. This system should never be used for lifting or moving people.
7. This system should not be used to suspend an object that is to be manipulated by a person. Always use positive support such as a table, chain fall, sawhorses, etc. in the event of a hydraulic failure, load shift, etc.
8. **Check your tire pressure.** You may find that it needs to be increased for use with the higher loads associated with pallet forks.
9. Inspect the frame occasionally for possible unseen damage. The areas around the loader attaching points and along the upper fork rail are where overstress damage would most likely be detected.
10. **The components of this system are electrically conductive.** Be aware of and avoid any sources of electrical power with this system.
11. All safety guidelines illustrated in your machine and loader owner's manuals should be observed whenever using an Artillian Pallet Fork System. In the event of conflicting information found here, defer to your machine owner's manual.
12. **This product is designed FOR PERSONAL USE ONLY by the original purchaser. It is not to be used for commercial applications such as for rental equipment or commercial construction. Any such use voids warranty.**

KIT INSTALLATION

Pallet Fork Frame Unpacking and Mounting

If unpacking your Artillian Pallet Fork Frame from a shipping box, you do not need to lift it. Simply open one end of the box to see inside. Then:

1. Orient the box so the fork rails are facing down and the mounting points are facing up. See Fig. 1.
2. Peel away and remove the packing materials until the mounting points are exposed.
3. Approach the fork frame with the tractor. "Dump" or tip the loader mounts downward and engage the pallet fork frame attaching points with the loader mounts.
4. Raise the frame up to waist height and curl it back until the loader locking pins can engage into the holes in the pallet fork frame.
5. Shut off the engine and/or set the parking brake.
6. Swing the levers to drop the securing pins into the lower holes in the pallet fork frame.

Alternatively, you can remove the frame from the shipping box and packing materials, lift the frame up, and set it onto the loader mounts. Swing the levers to drop the securing pins into the lower holes in the pallet fork frame.

If your Artillian Pallet Fork System came fully assembled on a pallet (such as for orders picked up at Artillian), simply follow the attaching instructions in the DAILY USE AND OPERATION section.

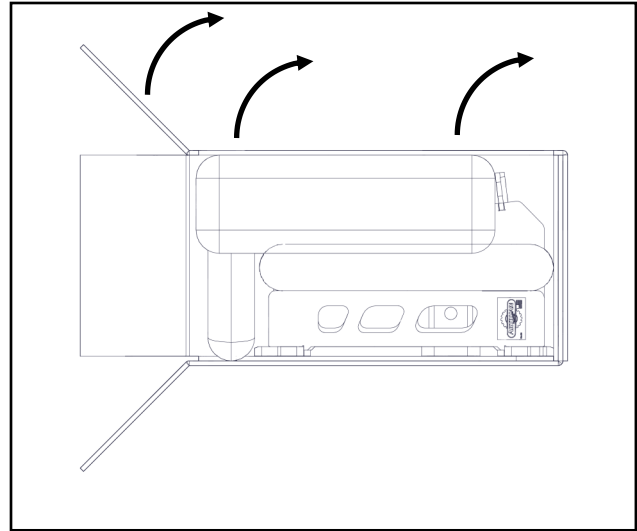



Fig. 1; Remove Fork Fame from Box

ATTACHING ATTACHMENTS TO FORK FRAME

Attaching the Fork Tines to the Pallet Fork Frame

To mount the fork tines on the fork frame, first attach the Artillian frame to your loader (see above), then mount each fork tine onto the frame, one at a time.

1. Attach the fork frame to your loader. Raise to a comfortable height, i.e. knee high or waist high. Using proper lifting techniques, pick up a fork tine and hang its upper clip at the **middle** of the upper fork rail.
2. Swing the bottom clip of the fork tine through the gap in the middle of the lower rail.
3. Raise the fork's locking pin (see DAILY USE AND OPERATION on the next page) and slide the fork left or right as desired, then lower the locking pin into one of the notches to secure it in place. Repeat for the opposite fork. Your Artillian Pallet Fork Set is now ready for use.
4. Removal of fork tines is the opposite of installation.

 Sliding fork tines on and off the ends of the fork frame is not recommended. A fork tine can bind and may fall when it becomes dislodged.

Optional Backrest (model 5-BR)

If your tasks or habits would benefit from a taller fork frame, we offer an optional Backrest. There is no modification required to install. It attaches to the fork frame very simply and remains in place with two simple pins. Our Backrest raises the rear elevation to 29" and is rated for a 500 Lb. load against the top edge. Please see the Artillian website for more information and ordering.

Backrest Maximum Loading

When properly attached to the pallet fork frame, the Backrest is designed to withstand a maximum load of 500 Lb. (225kg) applied perpendicular to the uppermost edge of the Backrest frame.

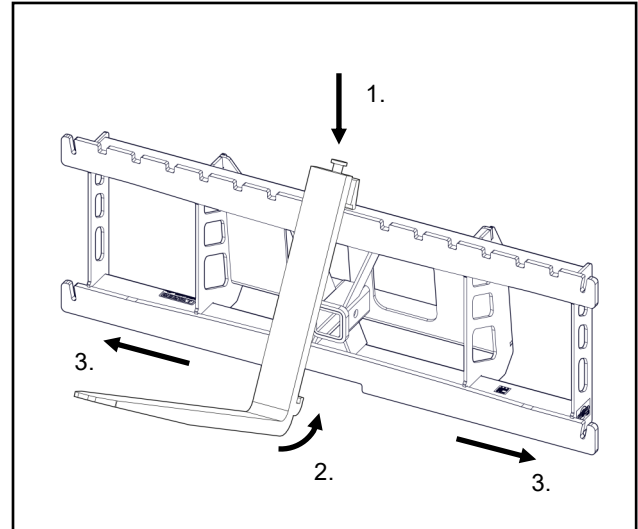

Fig. 2; Install Fork Tines

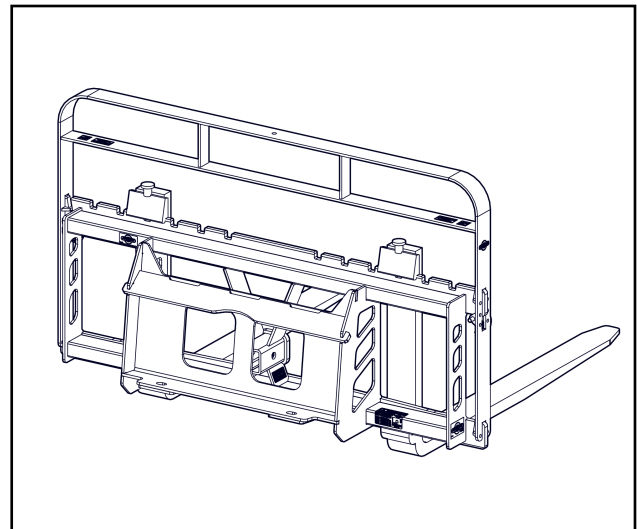

Fig. 3; Backrest Installed on Fork Frame

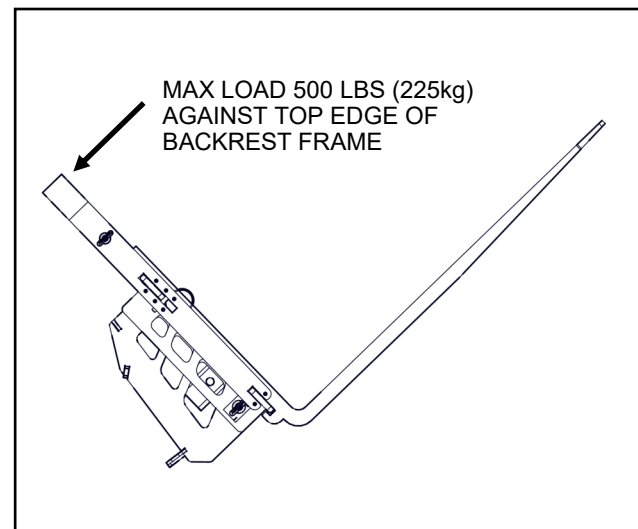

Fig. 4; Max Load on Backrest Frame

ATTACHING ATTACHMENTS TO FORK FRAME

Attaching the Fork Tines to the Pallet Fork Frame

To mount the fork tines on the fork frame, first attach the Artillian frame to your loader (see above), then mount each fork tine onto the frame, one at a time.

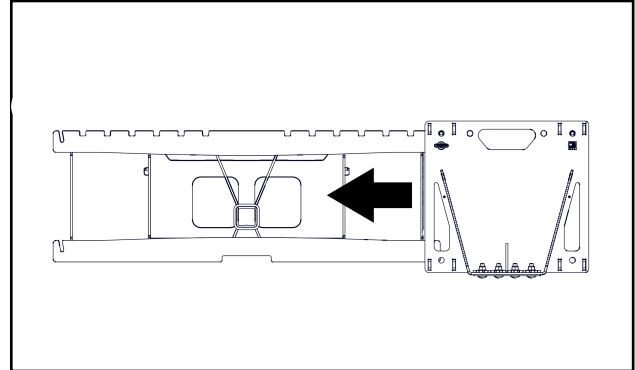

Fig. 5; Installing Optional Attachments

DAILY USE AND OPERATION

Attaching the Assembled Pallet Fork System to the Loader

Once the system has been assembled (see ASSEMBLY), attaching the pallet fork system to your loader is performed as follows.

1. Release the levers and remove any attachments (e.g. bucket) from your loader mounts.
2. Approach the backside of the Artillian pallet fork frame with your machine. Tilt the loader mounts forward so that the upper attaching points fit under the mating points on the fork frame.
3. Catch and lift the frame off of the ground slightly and curl the loader back fully.
4. Shut off the engine and/or set the parking brake.
5. Swing the levers to drop the securing pins into the lower holes in the pallet fork frame.
6. Your pallet fork set is now ready to use. To remove, reverse these instructions.

Adjusting the Fork Tines

To adjust the position of the fork tines from left to right, their locking pins must be released. To perform this with the Cascade fork tines, lift the pull pin and rotate 180° to lock the pin in the raised position. Slide the fork tine to the desired location and then turn and lower the lock pin into a detent slot on the fork rail.

When sliding the fork tines from side to side, they tend to move more easily if the forks are tilted downward until the weight of the fork is hanging on the upper fork rail primarily by its upper clip. After your fork set has been in use for a while, you may be able to slide the forks very easily using this method.

When your fork set is new, movement may be a little stiff. With use, the parts should wear in a bit and move more smoothly. When sliding the fork tines along the mounting rails, keep them hanging straight down. Tipping to one side while sliding may cause binding.

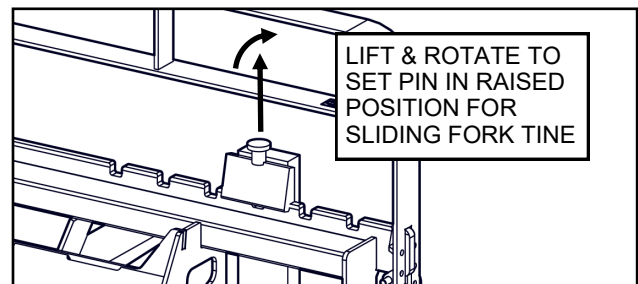

Fig. 6; Adjusting Fork Tines, Part 1

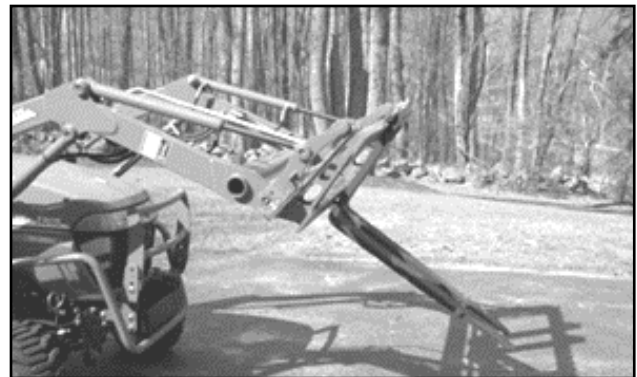



Fig. 7; Adjusting Fork Tines, Part 2

DAILY USE AND OPERATION

Use of the Pallet Fork Set

 When carrying a load on your forks:

- ALWAYS KEEP THE LOAD AS LOW AS POSSIBLE for the task at hand.
- Keep the load as far back toward the loader as safely possible.
- Keep the load curled back as far as practical to prevent the load from falling forward.
- Keep in mind that the level of the load may need to be adjusted for changes in grade.
- More ballast is necessary while sloping downhill than on flat ground or sloping uphill.

 When transporting from one location to another with no load, ALWAYS KEEP THE TIPS OF THE FORK TINES CURLED UPWARD so that:

- You will know where they are for ease of maneuvering, and
- They cannot inadvertently strike or gouge any objects in your path or plunge into the ground.

 When parked, always rest the fork tines flat on the ground to prevent tripping hazards.

Chain Slots

There are chain slots built into the fork rails, which can be used for securing loads or for lifting. The slots are designed for 5/16" chain of Grades 30 Proof Coil, 43 High Test, or 70 Transport.

 **DO NOT USE THE CHAIN SLOTS FOR PULLING.** If the chain becomes dislodged from the chain slot, something could snap back toward you or others in the area.

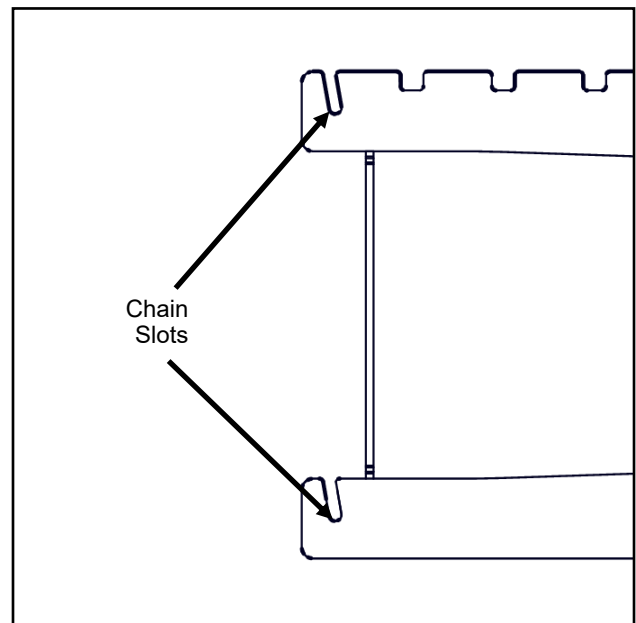

Fig. 8; Chain Slots on Fork Frame (Right Side)

MAINTENANCE

The system is largely maintenance free. However, you may occasionally apply lubricant to the beveled face on the backside of the upper fork rail where the fork tines interface.

The faces of the fork rails have additionally been treated with a dry film graphite coating on top of the powder coating. This is to help attachments slide more easily and offer yet another layer of protection over the powder coating. This graphite coating will become more lubricious with some use. It will also become scratched and scuffed over time. This is normal. If desired, it can be touched up with any commercially available dry film graphite lubricant.

SPECIFICATIONS

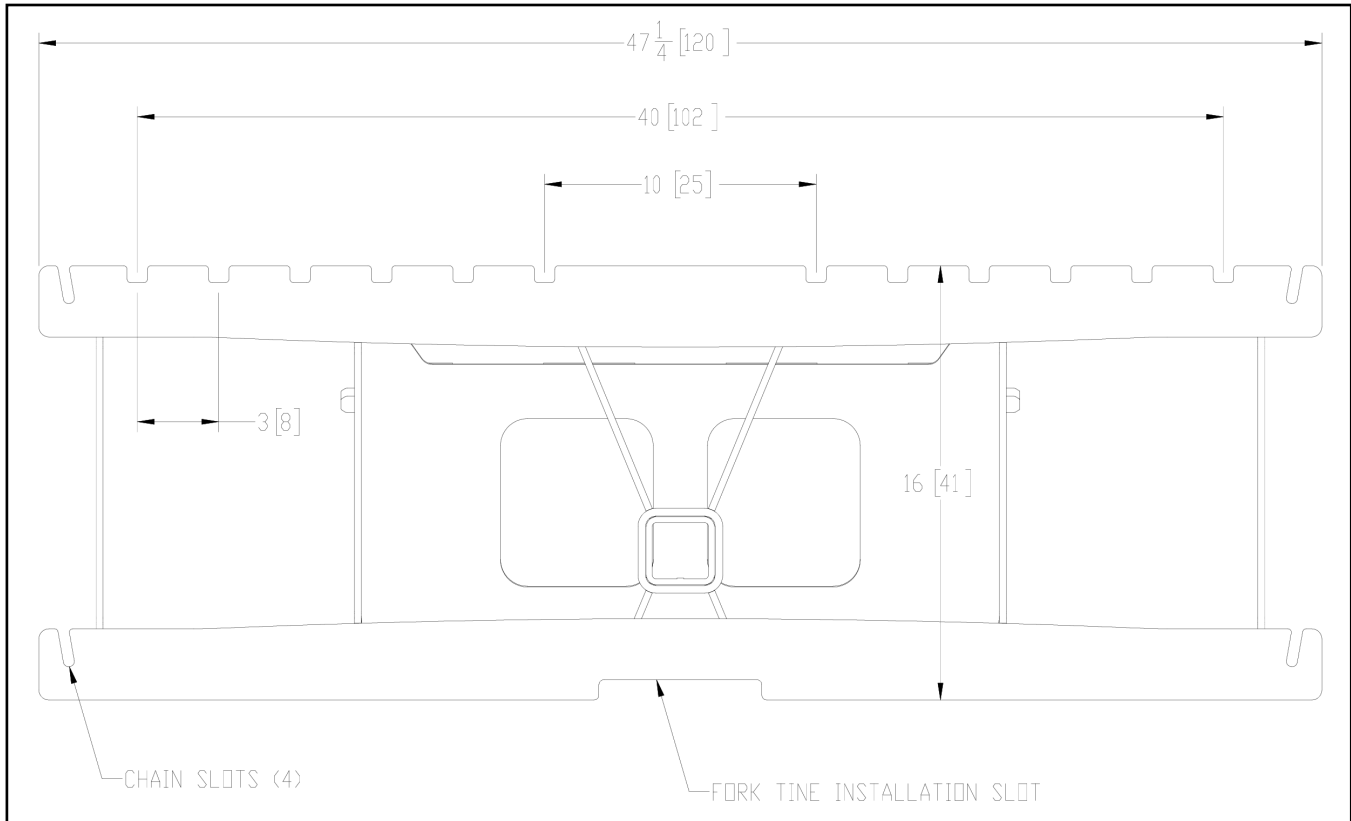

Pallet Fork Frame, Mini Skid Steer Dimensions (inches [cm])

Artillian FF-30-MSSHR Pallet Fork Frame

Weight	103 Lbs. (47kg)
Format	Common Industry Interface (CII)
Rail Width	47-1/4"(120cm) Overall
Notch Width	10"(25cm) min - 40"(102cm) max @ 3"(7.6cm) increments
Max Load	3000 Lbs. (1360kg) at an 18" (450mm) load center
Material	High Strength Carbon Steel, all North American origin
Finish	Powder Coat Poly Black. Fork rail faces coated with dry film graphite lubricant

SPECIFICATIONS

Pallet Fork Set Maximum Loading

The lift capacity of a pair of fork tines is defined as an amount of weight centered at a distance from the heel (bend) of the fork tine. This is referred to as the "LOAD CENTER" (LC). Please refer to the decal on the pallet fork frame to determine the capacity of your fork set based on the fork tines being used.

Regardless of fork tines used, the Artillian Pallet Fork Frame is limited to a maximum load of 3000 Lbs. (1360kg) at an 18" (450mm) load center.



CAUTION

MAXIMUM LOADING

STANDARD TAPER TINES
 48"x4" - 3000LB @ 18" LC
 42"x4" - 3000LB @ 18" LC

FULL TAPER TINES
 42"x4" - 2500LB @ 18" LC
 42"x3" - 2300LB @ 18" LC
 36"x3" - 2300LB @ 18" LC
 24"x3" - 1800LB @ 12" LC

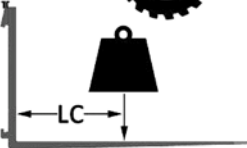
**NON-COMMERCIAL
USES ONLY**

Position of Load vs Lift Capacity

This graph gives an example of how the lift capacity of a set of forks decreases as the load center moves out toward the tips of the tines. For maximum lift capacity, keep the load as close to the loader as possible.

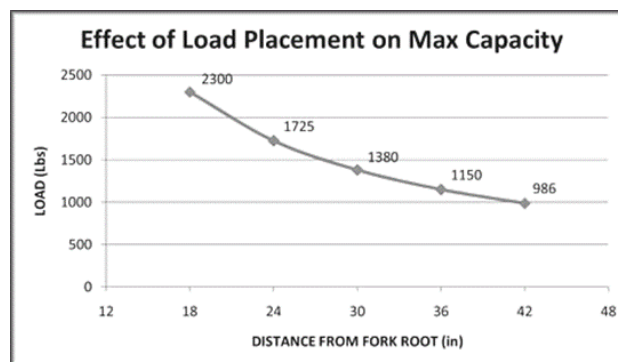

Serial Number Tag

The serial number of your pallet fork frame can be found on a decal placed on the underside of the upper fork rail within the area of the structural framework.

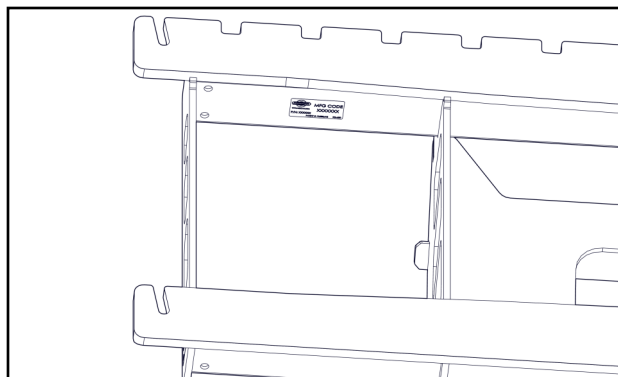

2" Hitch Receiver Maximum Loading (Optional)

CAUTION: The 2" Hitch Receiver is NOT to be used for axial loads, such as plowing.

When using the optional 2" Hitch Receiver, a total of 3000 Lbs. (1364 kg) of force can be applied vertically and a total of 2000 Lbs. (909 kg) may be applied horizontally to the ball mount at a distance of 12" from the back end of the Hitch Receiver Tube.

Be cautious when using the 2" Hitch Receiver to move trailers, especially on hills. Keep turns shallow so as not to allow the trailer to apply excessive side loading to your machine, resulting in rollover or other loss of control.

Note: Usability of the 2" Hitch Receiver may be limited on some front end loaders, such as on skid steer machines having a solid cross member (butterfly) style quick attach mount.

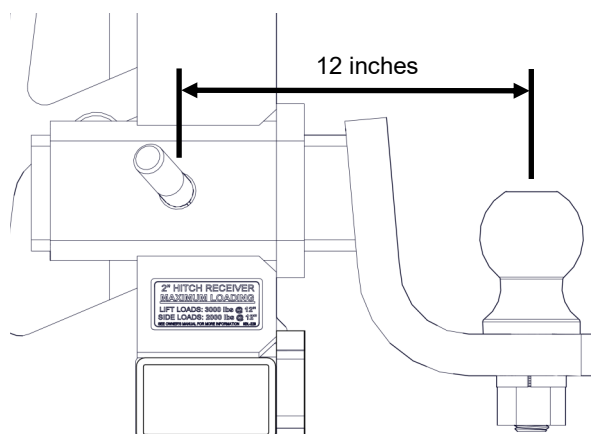

AVAILABLE ATTACHMENTS:

BACKREST, REMOVABLE, PALLET FORK FRAMES; P/N: 5-BR

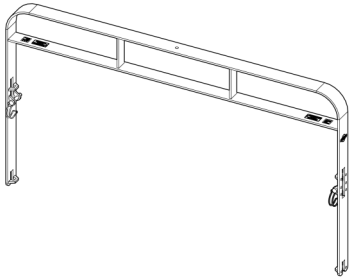

36" X 3" STANDARD TAPER FORK TINE PAIR; P/N: FTC-363S
 42" X 3" STANDARD TAPER FORK TINE PAIR; P/N: FTC-423S
 42" X 4" FULL TAPER FORK TINE PAIR; P/N: FTC-424F
 42" X 4" STANDARD TAPER FORK TINE PAIR; P/N: FTC-424S
 48" X 4" STANDARD TAPER FORK TINE PAIR; P/N: FTC-484S

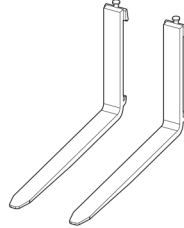

FRONTHOE BUCKET P/N: 5-FPS-916

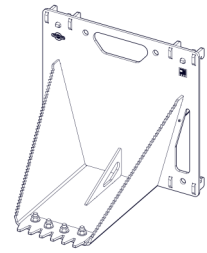

3-POINT CAT/SAE QUICK HITCH ADAPTER; P/N: 5-QHA

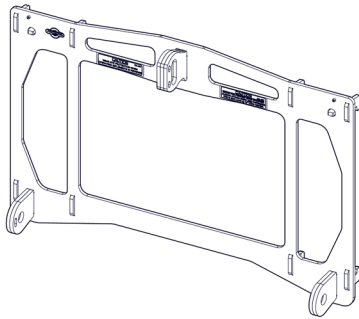

MODULAR GRAPPLE P/N: GRP-GP20-GR

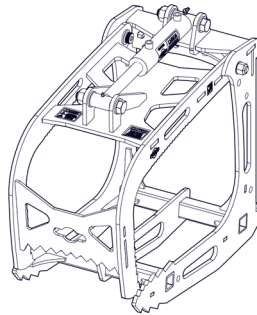

RAKE P/N: GRP-GP20-RK

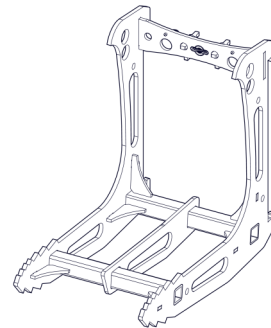

HYDRAULIC SPLITTER MANIFOLD DOUBLE PORT; P/N: HSM-SPM4P-F

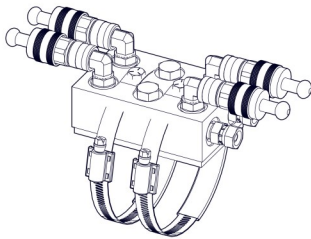

HYDRAULIC HOSE ASSY, VALVE TO MANIFOLD, 30" LG; P/N: HHA-HSM-30

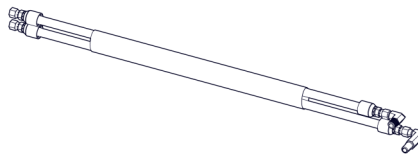

HYDRAULIC FITTING KIT, 1/2" FLAT FACE QUICK DISCONNECT; P/N: HFK-FFQD-500

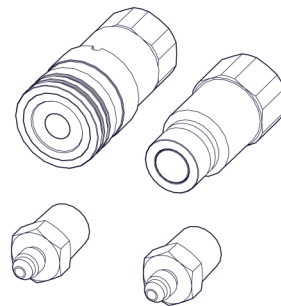

60" ARTILLIAN HYDRAULIC PLOW P/N: 1SPA-60HYD

72" ARTILLIAN HYDRAULIC PLOW P/N: SPA-72HYD

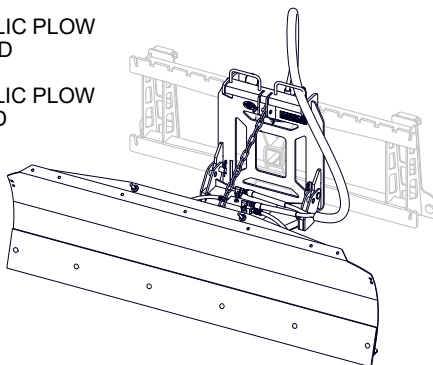

BALL HITCH, 2 INCH P/N: 1BH2IN

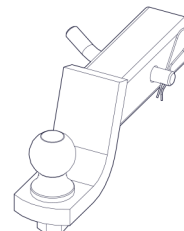

MORE ATTACHMENTS COMING SOON!

Warranty

Artillian, LLC warrants to the original purchaser that this product will be free from defects in material and workmanship for a period of **90 days** from the date possession taken by the original purchaser for use with Artillian hydraulic products and used as intended and under normal service and conditions for personal use. If not purchased for use with Artillian hydraulic products (e.g. Grapple, Plow Adapter, etc.), the warranty period is limited to **30 days**.

Finishes (coatings, labels, & decals) are not inclusive. Artillian, LLC reserves the right to inspect items claimed to be defective in material or workmanship. Artillian LLC's obligation under this warranty is limited to repair or replacement with a nearest similar part.

This Warranty will not apply to any part or product which in Artillian LLC's judgment shall have been misused or damaged by accident, abuse, misapplication, fire, negligence, or lack of normal maintenance or care, or which has been altered or repaired in a way which adversely affects its performance or reliability, or which has been used for a purpose for which the product is not designed.

Artillian, LLC's obligations under this warranty, to the extent allowed by law, is in lieu of all warranties, implied or expressed, including implied warranties of merchantability and fitness for a particular purpose and any liability for incidental and consequential damages with respect to the sale or use of the product warranted. In any event, liability on behalf of Artillian LLC is limited to the original purchase price.