



## Artillian Pallet Fork Caster Carts PFCC-3 & PFCC-4

Please review this information before using!

### ASSEMBLY INSTRUCTIONS:

The 4" Caster Wheel attaches at the front of the Caster Cart Frame. The 5" Caster Wheel attaches at the rear of the Caster Cart Frame.

1. Insert one bushing onto the Flange Head Screw as shown. Pass screw from bottom through caster wheel bolt hole.
2. Add second bushing over screw threads as shown.
3. Thread screw into welded hex nut on bottom of Caster Cart Frame. Tighten securely with 9/16" open end wrench.
4. Repeat for other wheel.
5. Insert T-Handle into welded hex nut on top of caster cart.
6. Repeat for second Caster Cart Assembly.

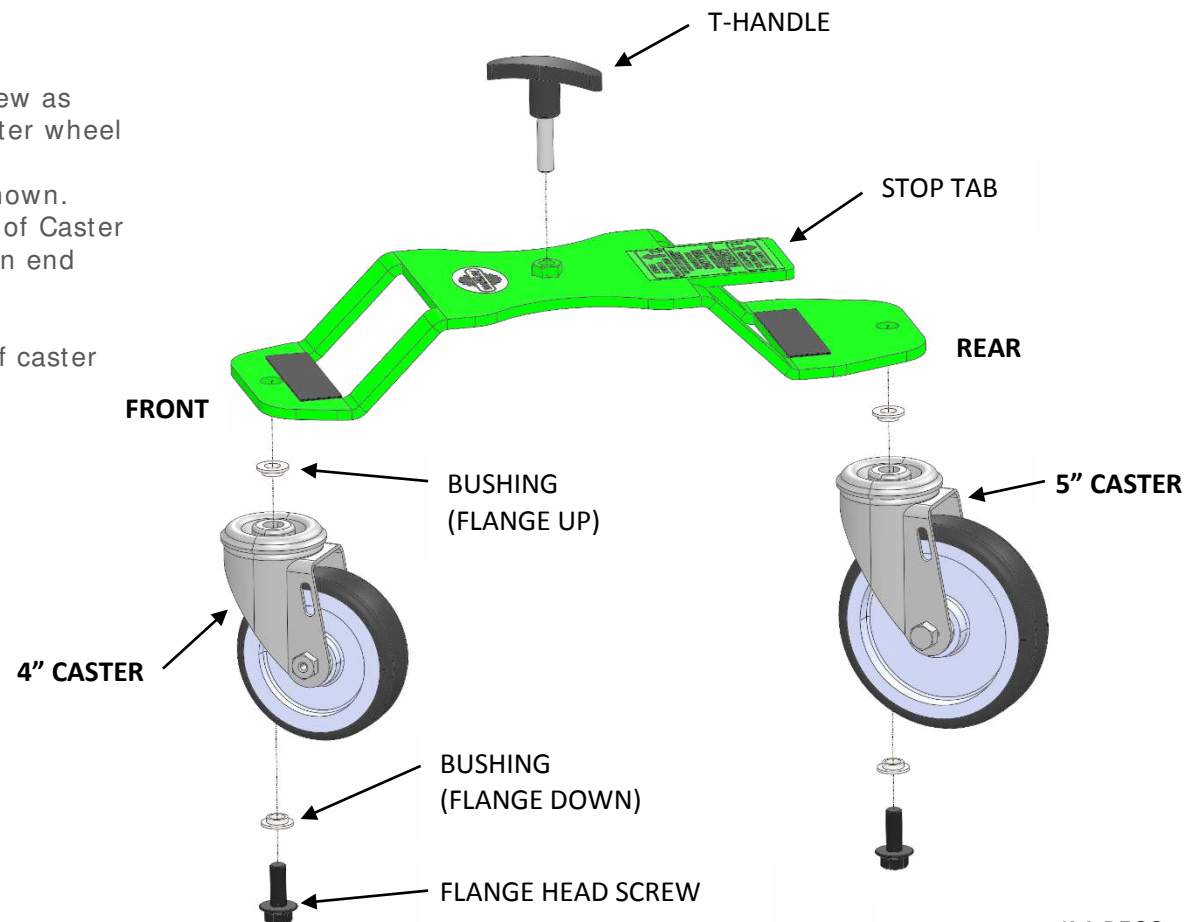



## Artillian Pallet Fork Caster Carts

PFCC-3 & PFCC-4

Please review this information before using!

### USAGE INSTRUCTIONS:

1. With fork set mounted on loader and raised to waist height, slide Caster Carts onto each fork tine all the way to the fork heel with the Stop Tab facing inward as shown below.
2. Hand tighten the T-Handle Screw to the fork tine enough so the cart cannot move.
3. Ensure that all caster wheels are unlocked and free to roll and rotate.
4. Prepare the pallet fork set for removal from the loader (for JDQA loaders, remove clevis pins)
5. Lower fork set towards the ground, setting Caster Cart wheels on the ground and simultaneously “dumping” loader to disconnect loader from fork set.
6. Fork set is now ready to be rolled away.
7. Removal is the opposite of installation.

### CAUTION

DO NOT ALLOW WEIGHT OF LOADER ARMS TO REST UPON THE CASTER CARTS WHILE DETACHING FORK SET.

CASTER WHEELS/CARTS ARE LIMITED TO 500 LB MAXIMUM LOAD

