

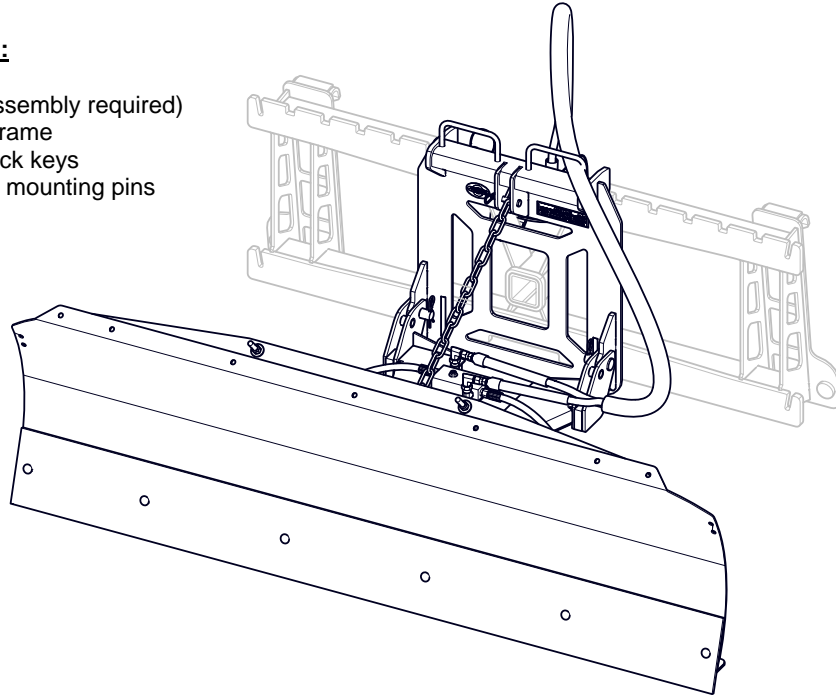

**Artillian 60" Hydraulic Plow  
SPA-60HYD  
for Artillian Pallet Fork Frames**

**Parts Included:**

- (1) Plow Kit (assembly required)
- (1) Mounting Frame
- (2) Tethered lock keys
- (3) Removable mounting pins



**Available Options:**

- 1. Blade Marker Kit (Set of 2) (P/N: 8SV-TBP37)
- 2. Extension Wing Kit, Reinforced Rubber (set of Left/Right) (P/N: ASW-60)
- 3. 60" Utility Vehicle Plow Snow Deflector Kit (P/N: 1UTV60SD)

**CAUTION:** This plow kit requires an Artillian Hydraulic Diverter Kit (not included). Be sure to install the appropriate kit for your tractor and loader's make and model.

**⚠ WARNING**

Do not attempt to install or operate this plow until you read and understand all warnings and instructions in this manual or on the plow. Failure to read all warnings and instructions could lead to serious injury or death.

**⚠ NOTICE**

ADDED WEIGHT

Curtis Cabs, blades and general accessories add additional weight to the base vehicle. All Curtis accessory weights are listed in product brochures. Deduct the accessory's total weight from the vehicle's rated capacity and never exceed the vehicle's rated capacity including driver and passenger.

Approximate Installation Time *
Experienced Dealer Technician – 1.5 Hours
Average Dealer Technician – 2 Hours
Do-It-Yourself – 3 Hours

(\* = Not including accessories)

Approximate Product Specifications
Weight: 207 lbs.**

(\*\* = Contents of this plow kit only)

The contents of this envelope are the property of the owner. Leave with the owner when installation is complete.

Thank you for choosing Artillian!

Rev. C, 1/15/2019

## TABLE OF CONTENTS

WARNINGS AND TIPS .....	3
CARE AND MAINTENANCE .....	3
TOOLS REQUIRED .....	4
PLOW ASSEMBLY .....	4-7
PLOW INSTALLATION .....	8-9
TROUBLESHOOTING.....	10
PLOW FEATURES & OPERATION .....	10
SERVICE PARTS .....	11

## WARNINGS AND TIPS

**! WARNING:** Cabs, blades, and general accessories add additional weight to the base vehicle. Deduct the accessory's total weight from the vehicle's rated capacity including driver and passenger. Never operate the vehicle outside of its rated weight capacity.

**! WARNING: Serious injury or death:**

- Never stand or ride on the plow assembly.
- Never operate the plow near pets or other people.
- Never leave the vehicle running unattended with plow attached.
- Never plow or carry plow at high speeds.
- Never clean or perform maintenance with plow raised.
- Never clean or service with plow in tripped condition.
- Never dislodge an obstruction with any part of the body.
- Warning - This attachment affects the handling performance.
- Warning - Before starting installation, park tractor in a flat area, ensure parking brake is engaged, and engine is turned off.
- Warning - Do not raise the loader and pallet fork frame above the tractor hood while using the plow, or damage may occur.
- Warning - Be sure to disconnect plow hydraulic lines from the front manifold before removing the plow from the tractor.

California Health and Safety Proposition 65 Warning: This product may contain chemicals known to the state of California to cause cancer and birth defects or other reproductive harm.

### HELPFUL REMINDERS:

- A. Check carton contents prior to beginning installation.
- B. Work in an organized area large enough to fit vehicle and plow.
- C. Have the required tools ready to speed up the installation time.
- D. Have a helper available to help move heavy parts and assemblies.

**The Installation should be done by “qualified personnel”.**

## CARE AND MAINTENANCE

- **Check and tighten all fasteners in the plow assembly and check all hydraulic fittings for leaks after initial use and every 5 hours of use thereafter.**
- **After every 10 hours of use, lubricate all pivot bolts, pins, snap lock latches, and any other moving parts in the plow assembly with all-season grease.**

# PLOW ASSEMBLY

## TOOLS REQUIRED:

- Set of standard and metric sockets
- Set of standard and metric open end wrenches
- One 3/8" drive ratchet
- Pliers
- Adjustable Wrench
- Thread sealer
- All season grease

## STEP 1: (Trip-frame to Moldboard)

**1.1** Per fig 1.1, locate the steel moldboard, trip frame, two 1/2-13 x 2 1/2" bolts, and two 1/2-13 Nylon lock nuts. Apply all-season grease to the mating surfaces on the trip frame and moldboard rib. As shown, line up the mounting hole in the trip frame with the mounting hole on the moldboard rib (near the bottom). Install into the mounting holes a 1/2-13 x 2-1/2" bolt as shown. Install a 1/2-13 Nylon lock nut on the back side of the bolt. Repeat installation of hardware for the right side, orienting the bolt head to face away from the center of the moldboard. Tighten the Nylon lock nuts until all thread slack is removed from the assembly while allowing the trip-frame to rotate freely.

<u>Hardware Used</u>	<u>Qty</u>
1/2-13 X 2-1/2" Hex Bolt	2
1/2-13 Nylon lock Nut	2

## STEP 2: (Trip Spring Installation)

**2.1** Locate the two trip springs, two eye bolts, two 3/8-16 Nylon lock hex nuts, and two 3/8" washers. Per Fig 2.1, hook one end of the trip spring through the lower trip spring mount. Hook the eyebolt on the other end of the spring and insert the threaded section up through the hole in the upper spring mount. Install a 3/8" washer, then a 3/8" Nylon lock hex nut on the eyebolt. Repeat above for the second trip spring.

<u>Hardware Used</u>	<u>Qty</u>
3/8-16 X 2-1/2" Eye Bolt	2
3/8-16 Nylon lock Nut	2
3/8" Flat Washer	2

**2.2** Set the spring tension by tightening the Nylon lock nut until a sheet of paper can slide between two coils on the spring. Be sure to set tension evenly in both springs.

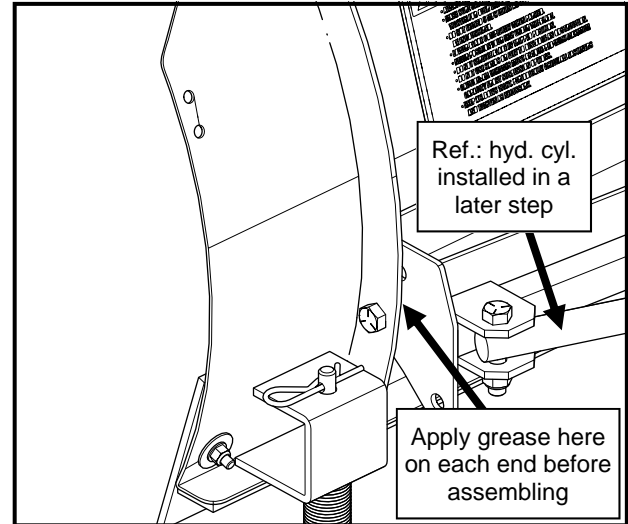

Fig. 1.1—Trip Frame to Moldboard

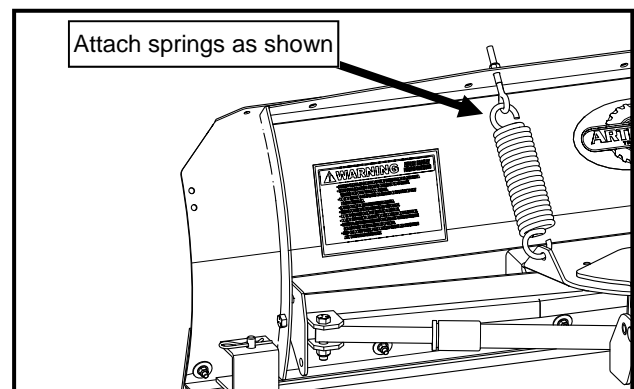

Fig. 2.1—Trip Spring Installation

# PLOW ASSEMBLY

## STEP 3: (A-Frame Installation)

**3.1** Per fig 3.1, locate the A-frame, one 1/2-20 x 3.5" hex head bolt, one 1/2-20 conical locking hex nut, and one 1/2" washer. Apply all-season grease to the top and bottom surface of the A-frame around and in the 1/2" bolt hole. Grease should extend about an inch away from the center of the hole.

**3.2** Per fig. 3.2, slide the A-Frame into the trip frame pocket, aligning the 1/2" bolt holes on both assemblies. Install the 1/2-20 x 3.5" hex head bolt with a 1/2" washer under the head of the bolt. Then thread on the lock nut. Tighten until all slack is removed from the bolt while the A-frame is allowed to rotate freely in the trip frame pocket.

<u>Hardware Used</u>	<u>Qty</u>
1/2-20 X 3-1/2" Hex Bolt	1
1/2-20 Distorted-Thread Lock Nut	1
1/2" Flat Washer	1

**3.3** Apply grease to the under side of the Pinch Guard in the area where it will contact the trip frame. Position the Pinch Guard bracket with the spacers down and with the four holes lined up with the corresponding holes in the top of the A-Frame. Fasten the bracket using four 1/2-13 x 1 1/2" hex head bolts and 1/2" lock washers. Make sure the A-Frame pivots in both directions.

<u>Hardware Used</u>	<u>Qty</u>
1/2-13 X 1-1/2" Hex Bolt	4
1/2" Split Lock Washers	4

## STEP 4: (Crossover Relief Valve Block)

**4.1** **NOTE: orientation is critical. Study figures 4.1 and 4.2.** Apply thread sealer to the male threaded ends of two NPT 1/4" male x 1/4" female 90° swivel elbows. Thread the elbows in where shown and tighten fully so that the swivel ends point straight up as shown. Apply thread sealer to the two NPT 1/4" male x 17" long high pressure hoses. Thread the two hoses into the end ports as shown and tighten fully.

**4.2** Per fig. 4.2, attach the bracket to the bottom of the block using two bolts and two lock nuts as shown.

<u>Hardware Used</u>	<u>Qty</u>
1/4-20 x 1-1/2" long Hex Bolt	2
1/4-20 Nylon Lock Nut	2

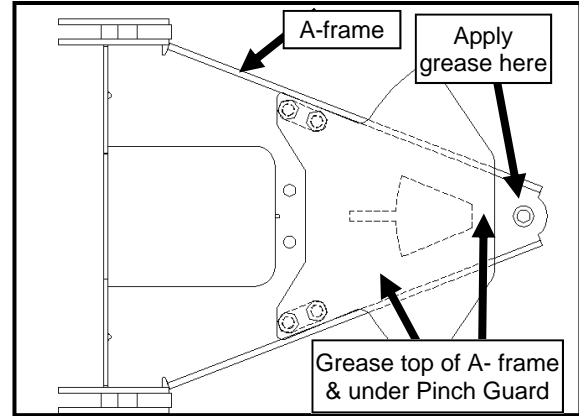

Fig. 3.1—A-Frame and Hardware

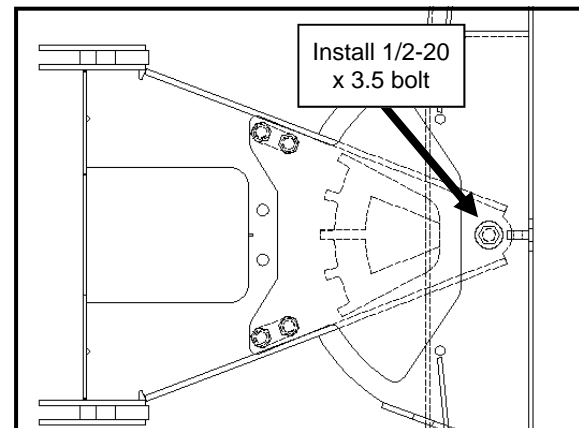

Fig. 3.2—A-Frame and Trip Frame

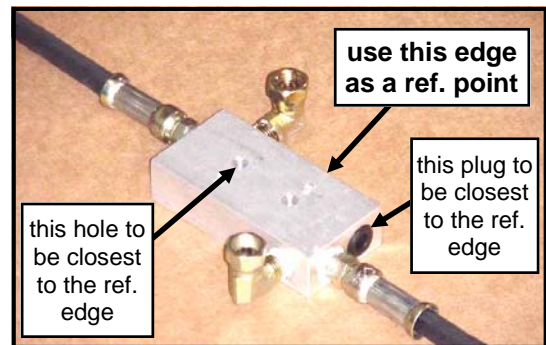

Fig. 4.1—Crossover Relief Valve Assembly

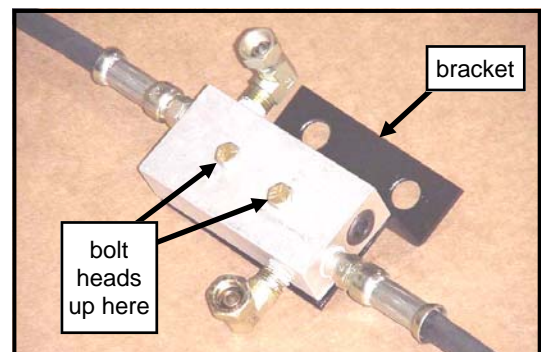

Fig. 4.2—Bracket Assembly

# PLOW ASSEMBLY

## STEP 5: (Hydraulic Angle Cylinders)

**5.1** Apply thread sealer to the male threaded ends of two NPT 1/4" male x 1/4" female 90° swivel elbows and thread into port on angle cylinder. Make sure the elbows point towards the ram end of both cylinders. See Fig. 5.1.

**5.2** See fig. 5.2. From below the A-frame, insert 1/2-13 x 4 1/2" long bolts through the lower cylinder brackets of the A-frame, the stationary ends of the angle cylinders, and the upper plate of the plow A-Frame. Place the fixed end of each angle cylinder into its respective bracket under the plow A-Frame. Orient the crossover relief valve block assembly as shown. Place the block assembly on top of the plow A-Frame and over the 1/2" bolts. Fasten and tighten using 1/2-13 lock nuts.

### Hardware Used

	<u>Qty</u>
1/2-13 x 4-1/2" long Hex Bolts	2
1/2-13 Nylon Lock Nuts	2

**5.3** Attach the ram end (moveable end) of the angle cylinders between the brackets at the outer ends of the back side of the plow trip frame using 1/2-13 x 2 1/2" bolts. Fasten and tighten fully using 1/2-13 lock nuts. See Fig. 5.3.

### Hardware Used

	<u>Qty</u>
1/2-13 X 2-1/2" Hex Bolt	2
1/2" Split Lock Washers	2

**5.4** Attach and tighten the free end of each of the 1/4" NPT x 17" long hoses, (previously installed in the crossover relief valve block) to the swivel elbow in its respective angle cylinder. See Fig. 5.4.

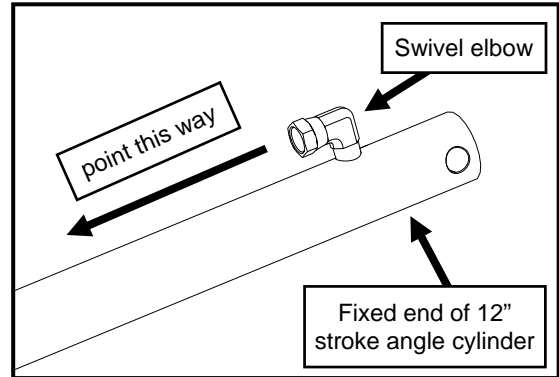

Fig. 5.1—Cylinder Fitting

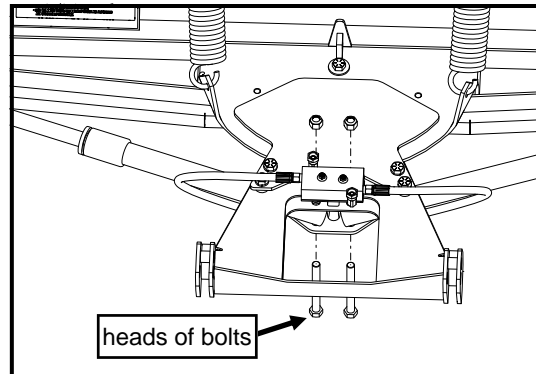

Fig. 5.2—Cylinder Fixed End

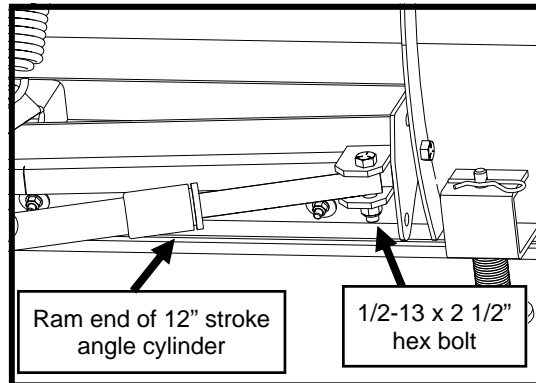

Fig. 5.3—Cylinder Ram End

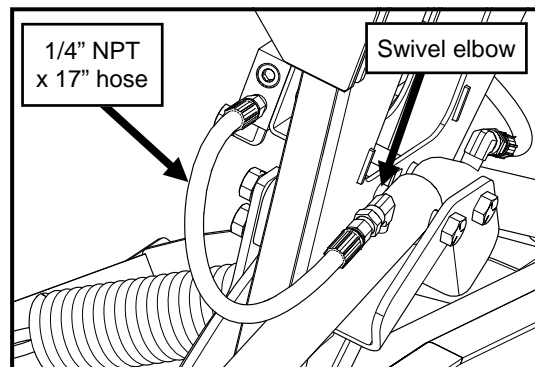

Fig. 5.4—17" Hoses to Cylinders

## PLOW ASSEMBLY

### STEP 6: (Quick-Disconnect Hoses)

- 6.1** Apply thread sealer to the male threaded ends of both hoses of the hydraulic hose assembly.
- 6.2** Study fig. 6.2. Hint: to help determine that you have the correct hose, hold the black-capped hose steady while moving the yellow-capped hose back and forth to confirm hoses. Reference: both hoses will be coming in from the left side of fig. 6.2. Connect the yellow-capped hose exactly where shown. Connect the black-capped hose exactly where shown.

**CAUTION:** Hose connections are intended to function so moving the Tractor joystick left will bring the left side of the plow closer to the operator, and right will bring the plow right side closer. Reversing the hose connections will reverse the direction of motion.

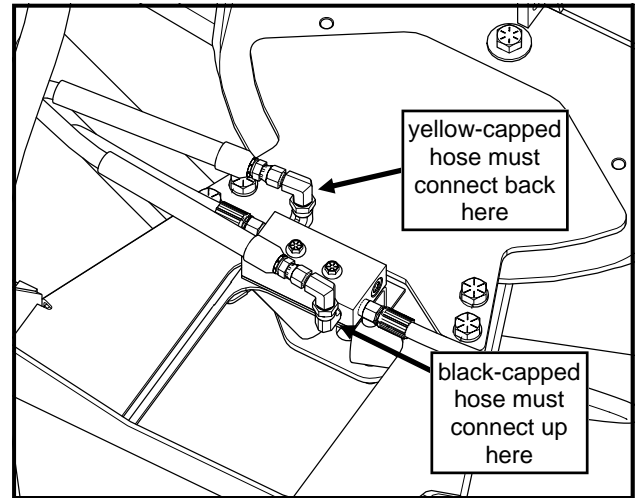

Fig. 6.2—Quick-Disconnect Hoses

### STEP 7: (Chain Shackle Installation)

- 7.1** Locate the Lift Chain Shackle per fig 7.1
- 7.2** Per fig 7.2, slide Lift Chain through shackle then insert the clevis pin on the lift chain shackle into the lifting hole on the trip frame. Slip Cotter pin into hole on clevis pin and bend back to lock in place.



Fig. 7.1—Lift Chain Shackle

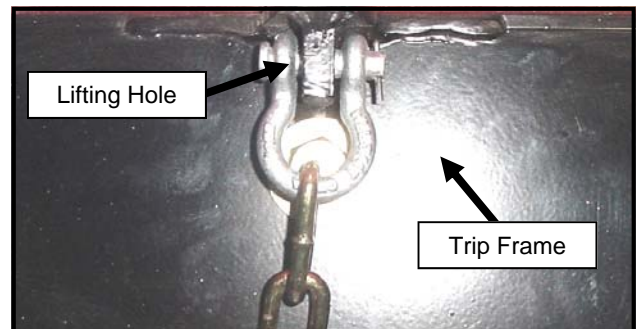

Fig. 7.2—Shackle installed on Trip Frame

## PLOW INSTALLATION

These instructions assume the Pallet Fork Frame and Hydraulic Diverter Kit are already installed onto the tractor.

### STEP 8: (Mounting Frame Installation)

- 8.1 Remove any attachments (i.e. fork tines) from the pallet fork frame.
- 8.2 Dangle the tethered lock keys over the front side of the mounting frame.
- 8.3 Hang the mounting frame by upper hooks on the fork frame rails. Hang one hook near the center of the fork rail and the other in one of the fork detents. Allow the mounting frame to rest flat against pallet fork frame so that both lower hooks pass under the bottom rail. See Fig 8.3
- 8.4 Pull the mounting frame up and slide it to the center of the pallet fork frame. **WATCH FOR PINCH POINTS AS YOU SLIDE THE FRAME ON.** See Fig 8.4
- 8.5 Pass the tethered lock keys through the detents on the fork frame and the holes in the mounting frame as shown in Fig 8.5. Push in until the locking lobe rests against the mounting frame and rotate until the locking lobe is hanging straight down. Be sure to install both keys.

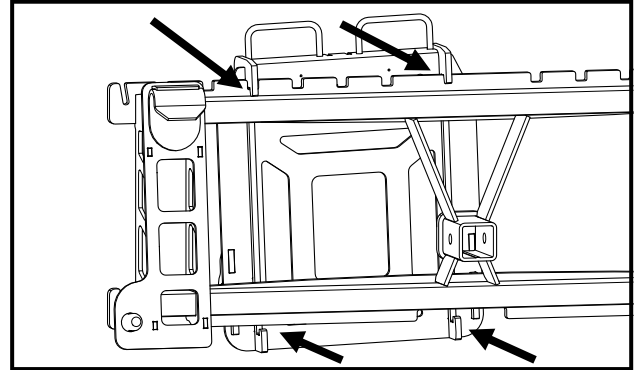

Fig. 8.3—Hang Mounting Frame onto Fork Frame

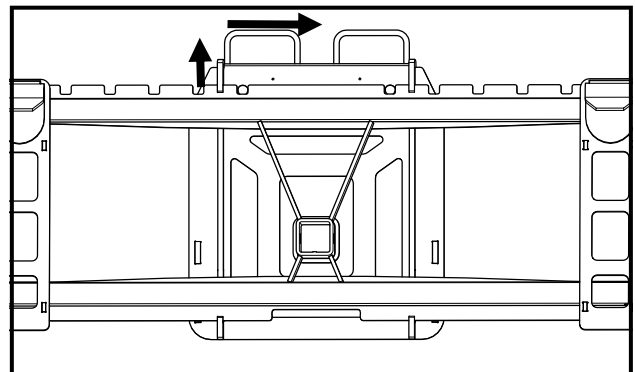

Fig. 8.4—Slide Mounting Frame onto Fork Frame

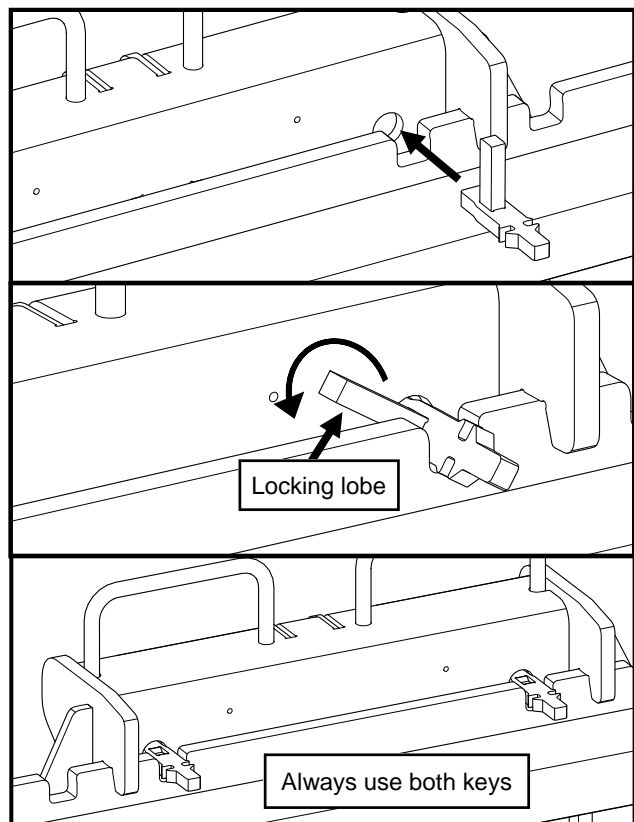

Fig. 8.5—Lock Keys



# PLOW INSTALLATION

## STEP 8: (Plow to Mounting Frame)

- 9.1** Place the Plow sub-assembly in front of the mounting plate and align the A-frame tabs to the lower tabs on the mounting plate. Connect the A-frame to the mounting frame with two 3/4" x 2" clevis pins and secure with the larger hairpin cotter pins. See Fig 9.1.

<u>Hardware Used</u>	<u>Qty</u>
3/4" x 2" Clevis Pin	2
1/8" x 2-5/8" Hairpin Cotter Pin	2

- 9.2** Connect the plow chain between the upper tabs of the mounting frame with a 3/8" x 2" clevis pin, with the pin through the third chain link, and secure with the smaller hairpin cotter pin. See Fig. 9.2.

<u>Hardware Used</u>	<u>Qty</u>
3/8" x 2" Clevis Pin	1
3/32" x 2-3/8" Hairpin Cotter Pin	1

- 9.3** Route the free end of the hydraulic hoses through the left handle of the mounting frame and connect to the front manifold of the Diverter Kit. Match the yellow and black capped hoses to the same colors on the diverter kit. See Fig. 9.3.

- 9.4** Once installation is complete, start your tractor and carefully actuate the plow and your loader through all ranges of movement. Cycle the plow left-to-right 5 to 10 times to bleed air from the plow hydraulics. See Plow Features and Operation on the next page.

**WARNING:** Do not raise the loader and pallet fork frame above the tractor hood while using the plow, damage or injury may occur.

- 9.5** Check for leaks and tighten any loose connections. Be sure the hydraulic hoses do not bind, kink or become stretched at any point. If this situation occurs, adjust hose routing as needed or contact Artillian. See step 10 on the next page if leaks are seen from either of the plow's hydraulic cylinders.

- 9.6** Top off the tractor's hydraulic fluid per the tractor's manual.

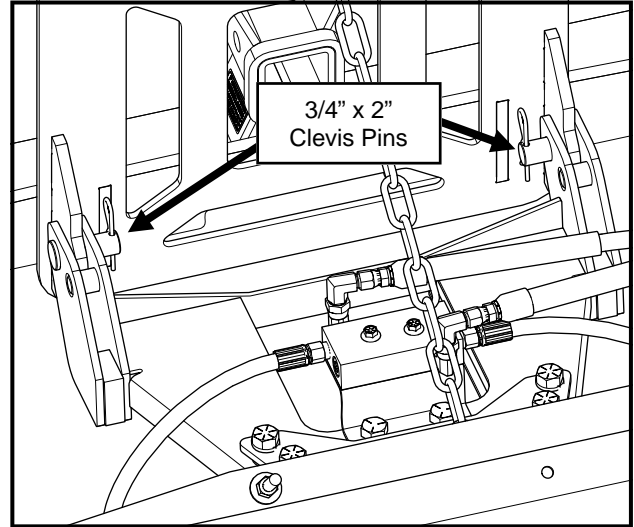

Fig. 9.1—Plow to Lower Mounting Tabs

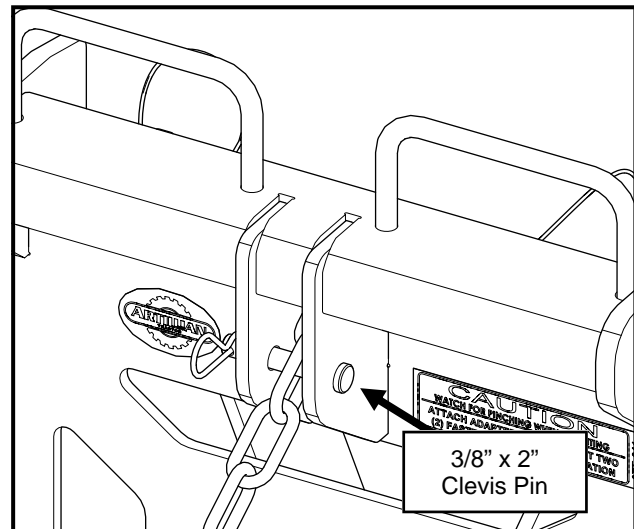

Fig. 9.2—Plow Chain to Upper Tabs

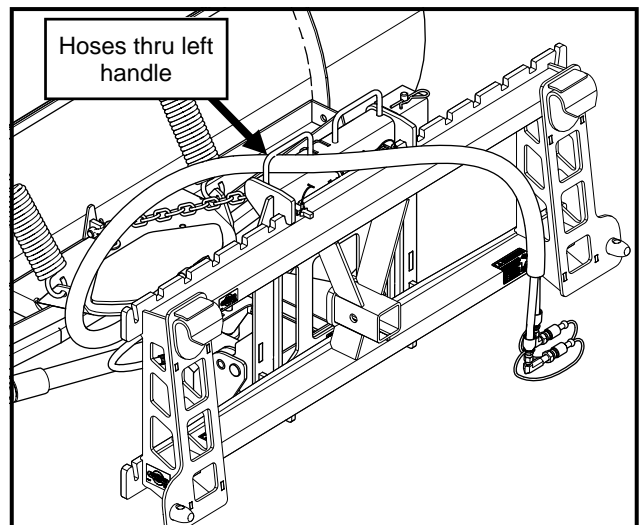

Fig. 9.3—Plow Hoses to Diverter Kit

## PLOW INSTALLATION

### STEP 10 (Hydraulic Cylinder Troubleshooting)

- 10.1 Oil seepage may stop on its own once the dry cylinders are fully cycled several times (5 to 10 times) to get the seals to reset properly. If this does not resolve the issue, proceed to step 10.2.
- 10.2 Per Fig. 10.2, loosen the gland nut on the particular leaking cylinder. Additional oil may escape. Take care to place a bucket or rags below the cylinder. Loosening the gland nut will allow the seals to relax and re-align. There is no need to remove the gland nut entirely. **Do not** remove the rod from the cylinder.
- 10.3 Hand tighten the gland nut.
- 10.4 Tighten the gland nut an additional 1/8 to 1/4 turn with a wrench.
- 10.5 Cycle the affected cylinder several times (5 to 10 times) to bleed air out of the cylinder.
- 10.6 Wipe down the cylinder with a rag and inspect for leaking oil.
- 10.7 If necessary, repeat the process of tightening the gland nut an additional 1/8 turn and bleeding the cylinder until free of leaks. Repeat another 1/8 turn if still leaking.  
Note: proceed only in 1/8 turn increments and continue cycle testing between adjustments.

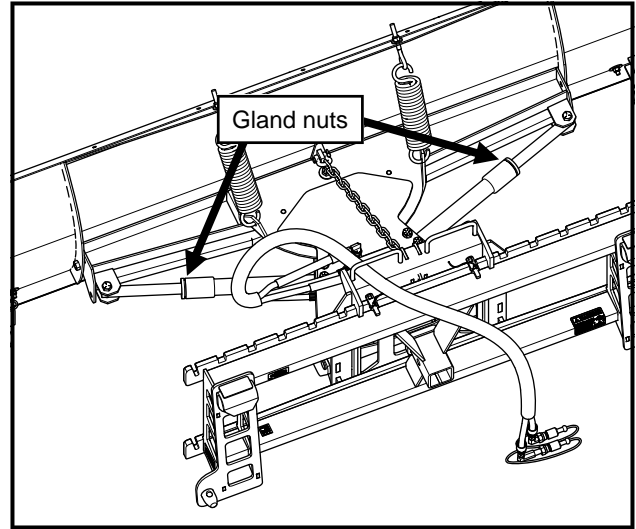
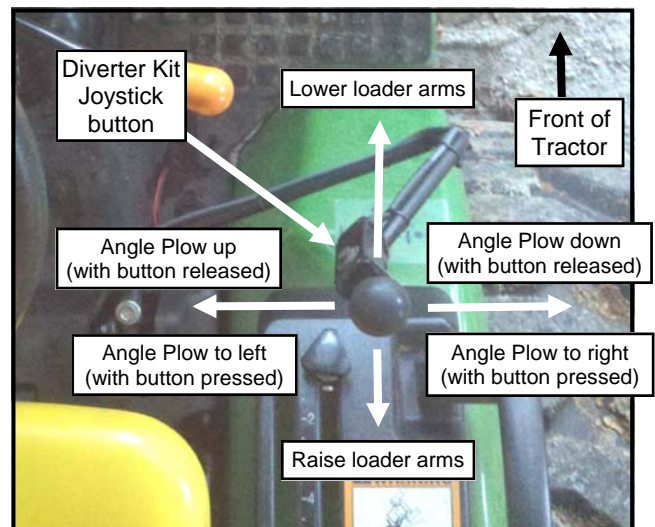

Fig. 10.2—Cylinder Gland Nuts

## PLOW FEATURES AND OPERATION

- For best results, keep the pallet fork frame as close to vertical as possible at all times.
- The loader arms and pallet fork frame must never contact or rest on the ground during plow operation, or damage may occur.
- Vertical angle of the Plow is controlled via the Dump/Curl function of the Tractor Loader Arms.
- Horizontal angle of the plow is controlled through an Artillian Hydraulic Diverter Kit, via the Dump/Curl function with the joystick button depressed.
- Moving the joystick to the left (with the joystick button pressed) brings the left side of the plow closer to the operator. Moving the joystick right moves the right side of the plow closer.

**WARNING:** Be sure to disconnect plow hydraulic lines from the front manifold before removing the plow from the tractor!



Typical Loader Arm Joystick

# ARTILLIAN 60" HYDRAULIC PLOW SERVICE PARTS

**STEEL MOLDBOARD ASSEMBLY**  
P/N: 8SV-204-00001

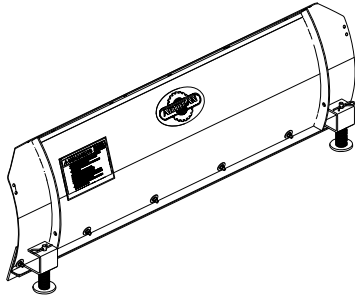

**A-FRAME ASSEMBLY**  
P/N: 8SV-TBP29LD1-B5

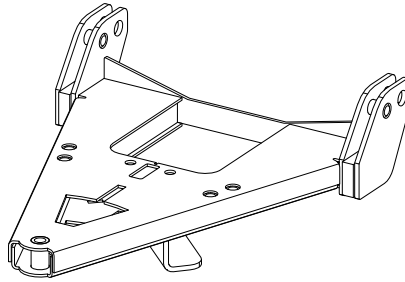

**MOUNTING FRAME**  
P/N: 8SV-201-00002

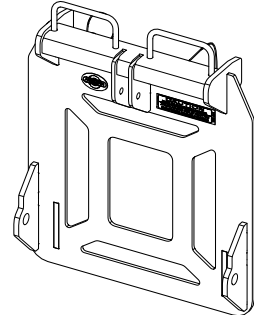

**PLOW TRIP FRAME**  
P/N: 8SV-KAF039P8-B5

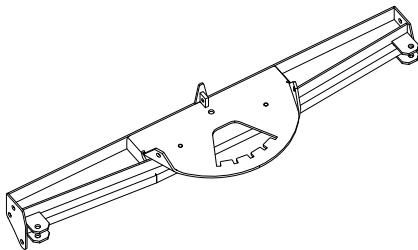

**HYDRAULIC CYLINDER 1" X 12" STROKE**  
P/N: V4207P1

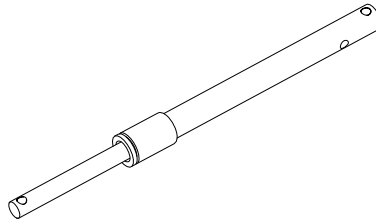

**HYDRAULIC HOSE ASSEMBLY**  
P/N: 8SV-HYA-00070

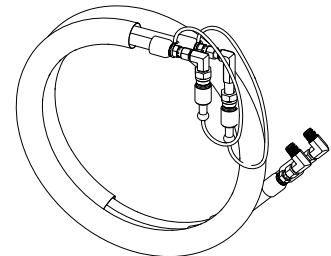

**A-FRAME PINCH GUARD**  
P/N: 8SV-TBP29PG-B5

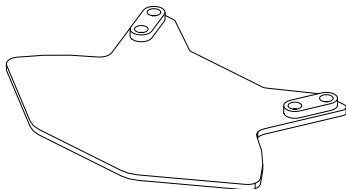

**CROSS-OVER RELIEF VALVE BLOCK  
BRACKET—P/N: 8SV-V4207P2**

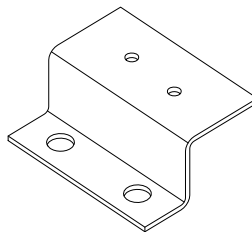

**CROSS-OVER RELIEF VALVE BLOCK**  
P/N: 1TBP71

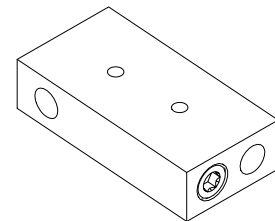

## ADDITIONAL SERVICE PARTS

PART NUMBER	DESCRIPTION
KAF550-038E	5' CUTTING EDGE FOR UTILITY PLOW, 1/4" X 6" X 60" (QTY: ONE)
UTV-SHOE	SKID SHOE (W/ HARDWARE) - (1/2" DIA ROD) ROHS COMPLIANT (QTY: ONE)
KAF25-039SP	TRIP SPRING (QTY: ONE)
8SV-WA-00142-ZY	ARTILLIAN KEYLOCK SERVICE KIT, LONG (QTY: ONE KEY)
9SV-V4207P4	HOSE, 1/4" NPT—M (BOTH ENDS) X 17" (QTY: ONE)
1TBP71-B	90° ELBOW, 1/4" NPT MALE X 1/4" NPT FEMALE SWIVEL (QTY: ONE)
9SV-HWK-00097	HARDWARE KIT, ARTILLIAN HYDRAULIC PLOW
V4208-18	4/0 X 19 LINK CHAIN, 26"L (QTY: ONE)
V4209-19	CHAIN SHACKLE W/ HARDWARE (QTY: ONE)