

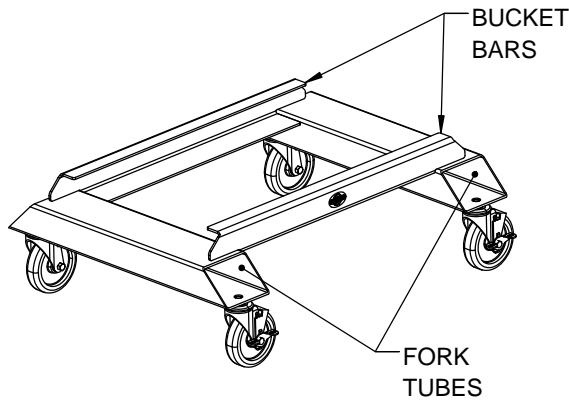

Assembly & Use of Your Artillian Fork-N-Bucket Cart

1000 Lbs Max Total Capacity / 250 Lbs per wheel



ASSEMBLY (IF REQUIRED)

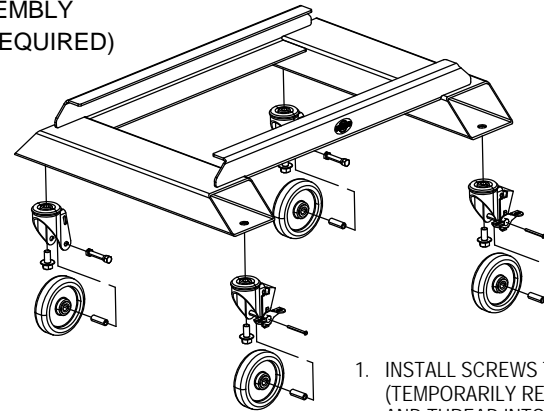

1. INSTALL SCREWS THRU CASTER MOUNT HOLES (TEMPORARILY REMOVE WHEELS IF NECESSARY) AND THREAD INTO WELDNUTS ON CART.
2. TIGHTEN SECURELY WITH A WRENCH

YOUR PALLET
FORK SET

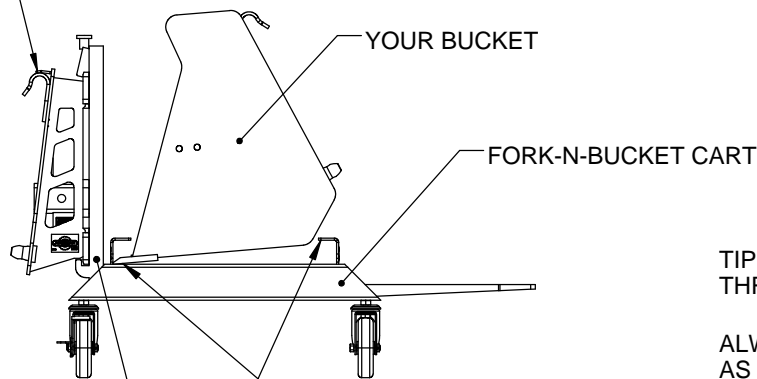

TO POSITION PALLET FORKS:

TO POSITION BUCKET:

A) CHOCK OR LOCK THE CART WHEELS. INSERT PALLET FORK TINES INTO THE "FORK TUBES" FULLY AND DISMOUNT FROM TRACTOR, OR

B) START THE FORKS INTO THE "FORK TUBES". THEN, LIFT UP AND SLIDE THE CART ONTO THE FORKS COMPLETELY. THEN, DISMOUNT FORKS AND CART FROM TRACTOR.

BUCKET CUTTING EDGE RESTS AGAINST "BUCKET BAR" IN FRONT OF BUCKET. REAR OF BUCKET RESTS AGAINST/ON TOP OF "BUCKET BAR" BEHIND BUCKET.

TIPS OF FORK TINES PASS THROUGH "FORK TUBES"

ALWAYS INSERT AS FAR AS THEY WILL GO!

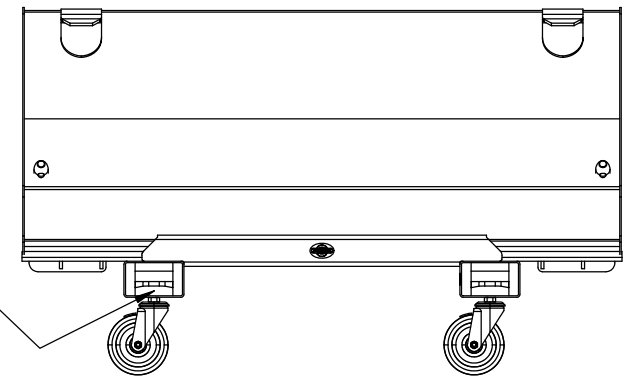

CAUTION

WATCH FOR OBJECTS IN PATHWAY WHEN ROLLING THAT MAY CAUSE LOAD SHIFT

FOR HOLDING

Chock wheels with a block of wood or lock casters to keep cart from moving while loading/unloading and during storage

FOR BEST SECURITY

Bind attachments to cart with ratchet straps during rolling and storage

CAUTION

USE ONLY ON FLAT SURFACES