



## ARTILLIAN ELITE ROPS LIGHT KIT P/N: 1RMLK



The Artillian Elite ROPS Light Kit contains two lights that mount to most square and rectangular tractor ROPS profiles. It utilizes curved slots and 3.19" X 2.69" square style U-bolts in order to secure the lights firmly to the ROPS. This can accommodate rectangular ROPS profiles up to 2" X 3". An integrated switch allows either light to be illuminated independently.

The innovation of the design is that the light can be rotated about the horizontal axis and then securely locked, preventing rotation, without the use of tools. This provides the user with the flexibility to fine tune the angle of each light to meet the requirements of the current work task or even have one light facing forward and one facing rearward.

Release the light from the locking feature by pulling outwards on the integrated grab handle / brush guard. Once the locking feature is disengaged, the light can freely rotate up to 360°. Reengage the locking feature, in 10° increments, by gently releasing the grab handle. An internal compression spring returns the housing back into the locking feature on the mounting plate, securing it in the desired position.

Included in the kit is: (1) Left-hand light assembly, (1) Right-hand light assembly, (1) mounting hardware kit, (1) wiring kit, and installation instructions – everything you need to install and power your lights!

The contents of this envelope are the property of the owner. Leave with the owner when installation is complete.

# KIT INSTALLATION

In order to accommodate various sized ROPS profiles, two different lengths of U-bolt have been provided. Please select the most appropriate size for your ROPS and discard the other two.

1. Choose the desired location for the left-hand light on the left side of the vehicle ROPS. By design, the integrated switch should be facing up when the light is facing forward. While keeping the lower edge of the light mounting bracket perpendicular to the ROPS, secure the left light bracket assembly to the ROPS. See fig. 1. The design of the light bracket accommodates various sized ROPS. Rotate the provided U-bolt against the ROPS when the nuts are tightened.

*Note: To avoid illumination obstruction if a cab enclosure has been or will be installed on the vehicle, the light bracket assemblies may be fastened to the top horizontal portion of the ROPS.*

2. Repeat Step 1 above on right side of ROPS.
3. Terminals have been provided to wire directly to the vehicle's battery. If wiring directly to the battery is not desired, locate an appropriate 12 volt power source on the vehicle.
4. Disconnect negative battery terminal.
5. Uncoil the provided red wire. Strip approx. 1/4" of insulation from both ends of the red wire. Crimp and heat shrink a provided female push-on terminal to each end. See fig. 5.
6. Uncoil the provided black wire. Strip approx. 1/4" of insulation from both ends of the black wire. Crimp and heat shrink a provided male bullet terminal to each end. See fig. 6.
7. Route the end of the red wire attached to the light (that has the factory installed female push-on terminal) through the large slot found on the underside of the left light bracket assembly and up through the switch hole.
8. Route one end of the long red wire with the previously installed female push-on terminal through the large slot found on the underside of the left light bracket assembly and up through the switch hole.
9. Install both of the female push-on terminals routed in steps 7 & 8 to the supplied switch. See fig. 9.

*Note: Do not install switch into the light bracket at this time.*

10. Attach one end of the long black wire with the previously installed male bullet terminal to the factory installed female bullet terminal attached to the black wire found on the left light. See fig. 10.
11. Repeat steps 7-10 on the right side of vehicle using the opposite end of the red and black wires.

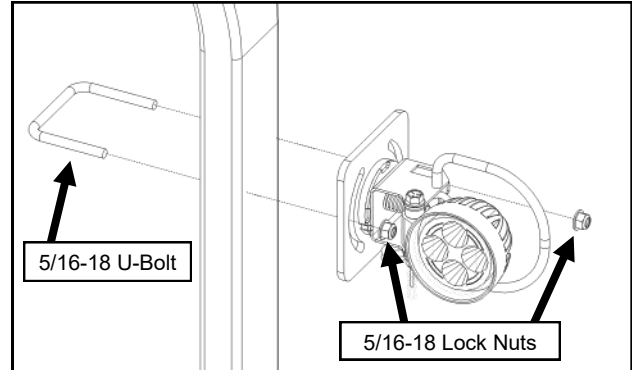

Fig. 1 (Left Light Bracket Assy. Orientation)



Fig. 5 (Female Push-on)

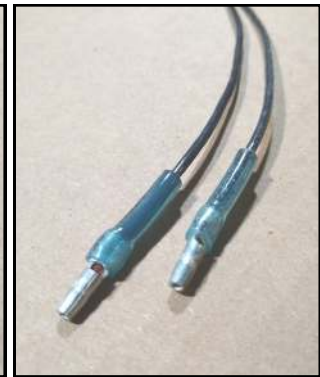

Fig. 6 (Male Bullet)



Fig. 9 (Red Wires to Switch)



Fig. 10 (Black Wire to Light Connection)

## KIT INSTALLATION

12. Begin to route the red & black wires down each of the vehicle's ROPS tubes. See fig. 12. Note: Due to the rotational feature of the light bracket assembly, be sure to leave approximately 8" of extra wire length at the light. Route the wires down either side of the ROPS, then toward each other using the shortest path. Note: It may be helpful to tape or zip tie wires together every few feet when routing.

**Caution: Be sure to keep wires clear from all heat sources and moving parts.**

13. Using the shortest path, route the two red wires together towards either the alternate 12 volt power source found in step 3 or the battery. Cut the red wire at the 12 volt power source or battery and strip approximately 1/4" of insulation from each end. Terminate the large end (indicated with a yellow line) of the provided step-down butt connector to both the red wires. See fig. 13. **Do not heat shrink until step 16.**

14. Cut and strip approximately 1/4" of insulation from the ends of the provided fuse holder. Install the supplied fuse into holder.

15. Crimp and heat shrink the provided 16-14GA. 5/16" ring terminal to one side of the fuse holder.

16. Crimp and heat shrink the fuse holder to the previously installed step-down butt connector. See fig. 16.

17. The fuse holder can now be secured to the positive terminal of the vehicle's battery.

18. Cut the black wire at the battery and strip approximately 1/4" of insulation from each end. Crimp and heat shrink the provided 12-10GA. 5/16" ring terminal to both of the black wires. See fig. 18.



Fig. 12 (Wire Routing)

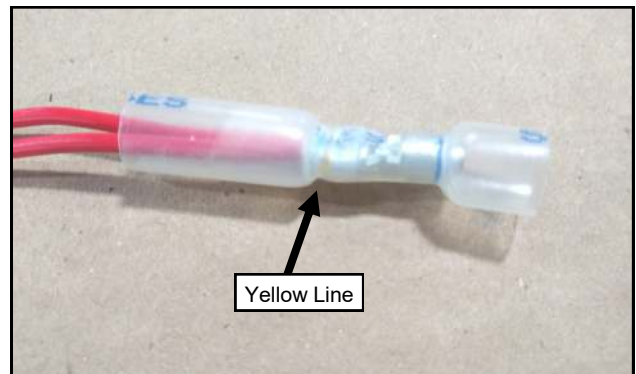

Fig. 13 (Step-Down Butt Connector to Red Wires)

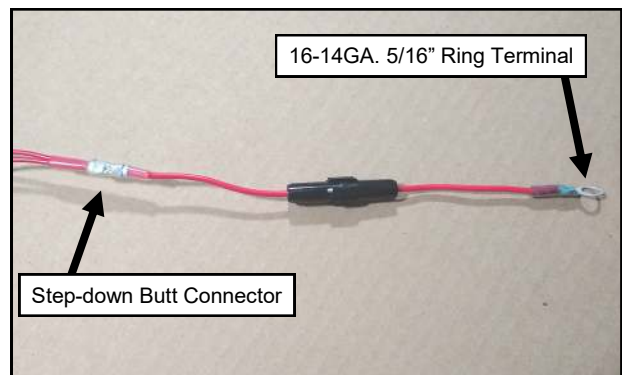

Fig. 16 (Fuse Holder Installation)

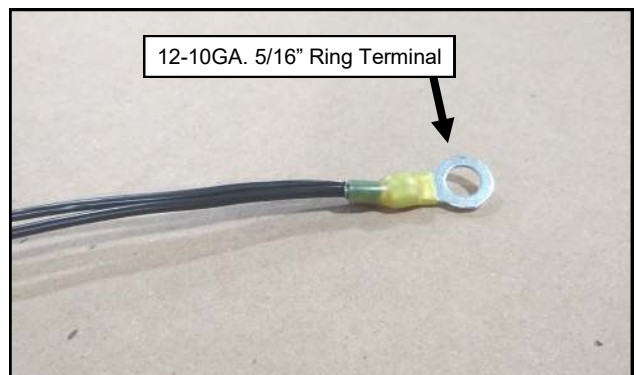

Fig. 18 (5/16" Ring Terminal to Black Wires)

## KIT INSTALLATION

19. Temporarily connect the previously installed ring terminal found on the black wires to the negative battery terminal. Reconnect negative battery terminal to battery. Test to make sure that both lights operate correctly. Once correct operation has been confirmed, disconnect the negative battery terminal.
20. Install the provided wire loom to all lengths of wire.
21. Install the switches into the light bracket assemblies. See fig. 21. (left side shown from rear of vehicle).
22. Due to the rotational feature of the light bracket assemblies, be sure to leave 6-8" of extra wire length by the lights. Secure harness with the supplied wire ties keeping clear from all heat sources and moving parts. See fig. 22.
23. Reconnect the negative battery terminal.



Fig. 21 (Switch Orientation)

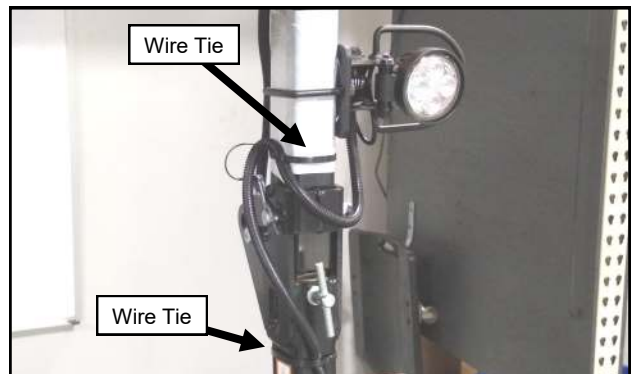
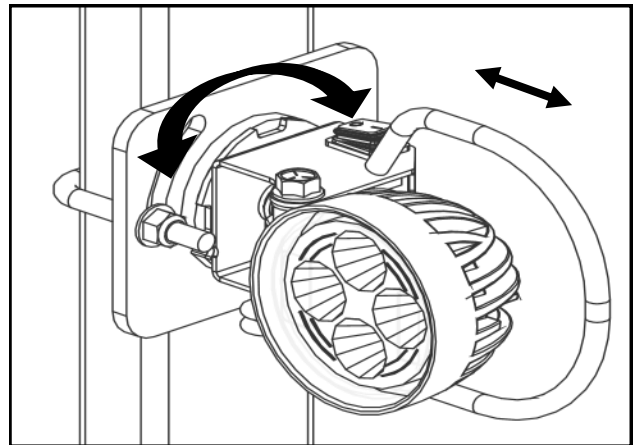
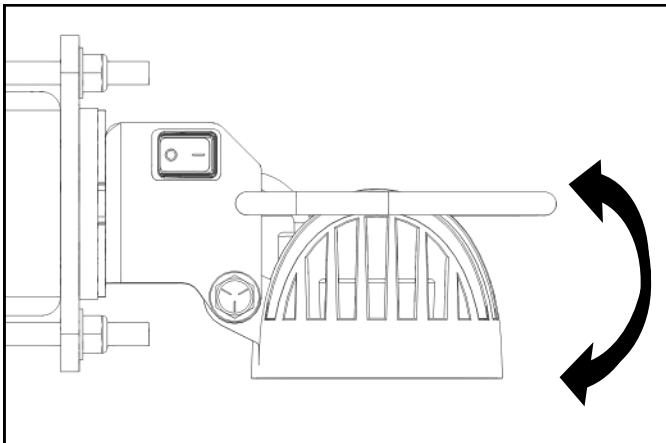

Fig. 22 (Secured Harness)

## LIGHT KIT FEATURES & OPERATION

### TOOL-LESS ADJUSTABILITY

For infinite adjustment of either light, whether working in front of vehicle or behind, it can be rotated in 10 degree increments and pivoted in or out 35 degrees. To adjust the light's clocking, simply pull handle straight out and rotate in the direction needed and allow light to re-engage into the nearest 10 degree position. The light can also pivot in or out by easily pushing by hand in the direction desired.



Note: When rotating either light assembly, it is recommended that when the operator turns in one direction and then wants the light to return to its original position simply reverse the direction of rotation. This will keep the wire harness from tightening up around the light assembly.

# ARTILLIAN PRO-SERIES ROPS LIGHT SERVICE PARTS

ROPS MOUNTED LIGHT ASSY, LEFT  
P/N: 8SV-113-00182-L

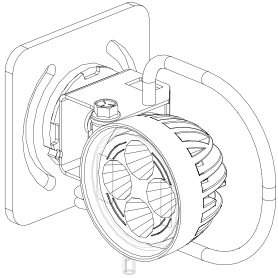

ROPS MOUNTED LIGHT ASSY, RIGHT  
P/N: 8SV-113-00182-R

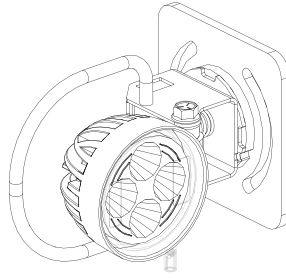

ELECTRICAL HARDWARE BAG  
P/N: 8SV-114-00033



ROUND LED UTILITY LIGHT  
P/N: 8SV-9LEDR-RMLK

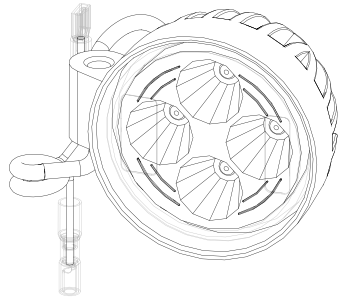

MINI ROCKER SWITCH, 2 POSITION  
SEALED  
P/N: 9SV-9RSM

