



22-DFHA – DEERE SUBCOMPACT QUIK-TATCH™ HITCH / 54 PLOW ADAPTER

FOR MOUNTING THE JOHN DEERE FRONT QUIK-TATCH™ HITCH FOR THE 2025R (2018+), 2210, 2305, 1023e, 1026r, 1025r SUBCOMPACT TRACTORS TO ARTILLIAN JDQA & JDPO FRAMES.

Contents

- (1) Adapter Plate
- (1) Solid Link
- (2) Tethered Lock Keys

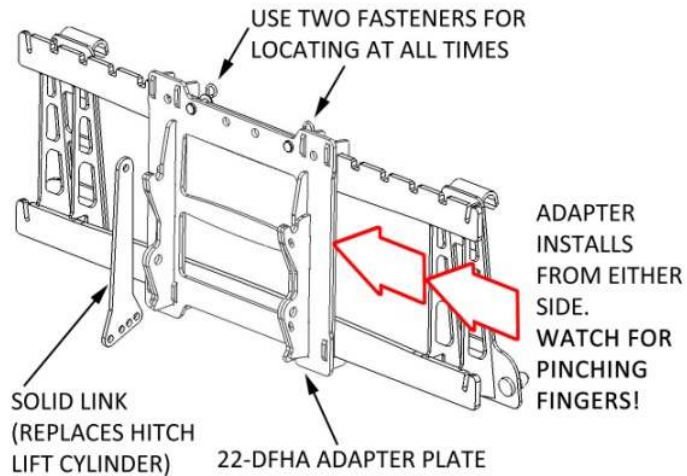

Installation

1. Remove the hydraulic lift cylinder (with hoses) from your Deere Quik-Tatch™ Hitch and replace it with the Solid Link. Choose any mounting hole for now for the bottom pin.
2. With your Artillian Pallet Fork Frame on your loader, remove any attachments (e.g., fork tines).
3. Hang the two tethered Lock Keys over the front of the plate and slide the Adapter onto the rails of the fork frame. Locate it at the middle of the frame.
4. Pass the tethered lock keys thru the detents on the fork frame and the holes in the Adapter Plate as shown in Fig 2 below. Locking lobe hangs straight down. Be sure to install both keys.

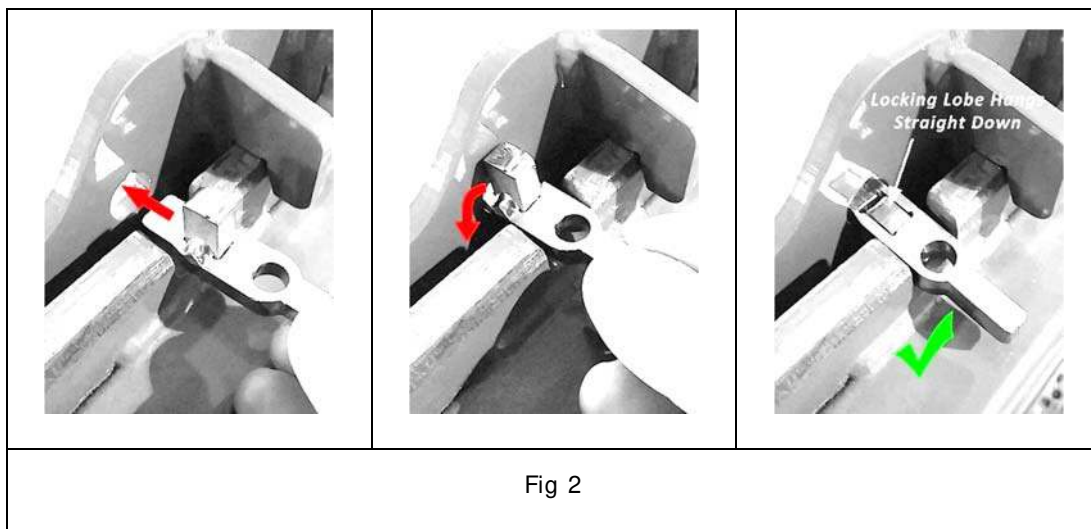

Fig 2

5. On the Quik-Tatch™ Hitch, set the two mounting pin fasteners (the “L” shaped spring levers) to the “open” position. (See Fig 3)
6. Approach the Quik-Tatch™ Hitch (with or without your blade attached) and engage the hooks of the Adapter Plate with the mounting rod of the Quik-Tatch™ Hitch. Adjust the loader position as needed until the side holes on the Adapter Plate can be engaged by the two “L” shaped pin fasteners on the Quik-Tatch™ Hitch.
7. Set the two “L” shaped pin fasteners on the Quik-Tatch™ Hitch to the “closed” position so that the two pins fall into the holes on the Adapter Plate. Some shifting may be required to settle the hitch completely onto the Adapter Plate and fully engage the pin fasteners.
8. The Quik-Tatch™ Hitch is now installed onto the Adapter Plate. Attach your blade to the hitch, if it isn't already.

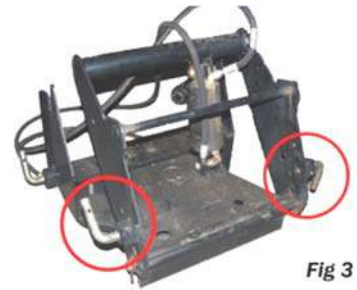

Fig 3

Adjusting the Solid Link

The graduated mounting holes at the bottom of the Solid Link enable adjusting the fore-and-aft pitch angle of the plow blade with respect to the ground and your loader.

1. Locate the tractor/plow on flat ground. The plow should be in its neutral position (not angled left or right).
2. **Curl the loader back fully to the hard stops.**
3. Rest the plow blade on the ground and put the loader into “float”.
4. Set the parking brake and shift to neutral.
5. Observe the plow cutting edge from the side. **Both the cutting edge and plow wear skids should be touching the ground.**
6. If the angle needs to be adjusted, raise the loader enough to take the weight off of the Solid Link. Change the hole used in the Solid Link to affect the angle accordingly.
7. Return the loader to the float position and check the plow angle again. Repeat until the plow is set at the proper angle.
8. Installation is now complete. After using the system for some time, readjustment may be desired.



Important Notes

- I. This information assumes the user is already familiar with the operation of the tractor, loader, the 54 Blade, and the Artillian Pallet Fork Frame.
- II. When using this system, **THE PLOW BLADE MUST BE ALLOWED TO TRIP.** NEVER use your plow with the trip lock engaged. Otherwise, you could damage your loader or Artillian frame. See your plow owner's manual for more information on setting the trip lock.



- III. This Adapter can be used at the center of the Artillian Frame, or offset to the sides. The graphics below demonstrate how to properly locate the adapter. This is important for safe use. Failure to follow these guidelines could cause the adapter to become dislodged from your Artillian Frame while in use.

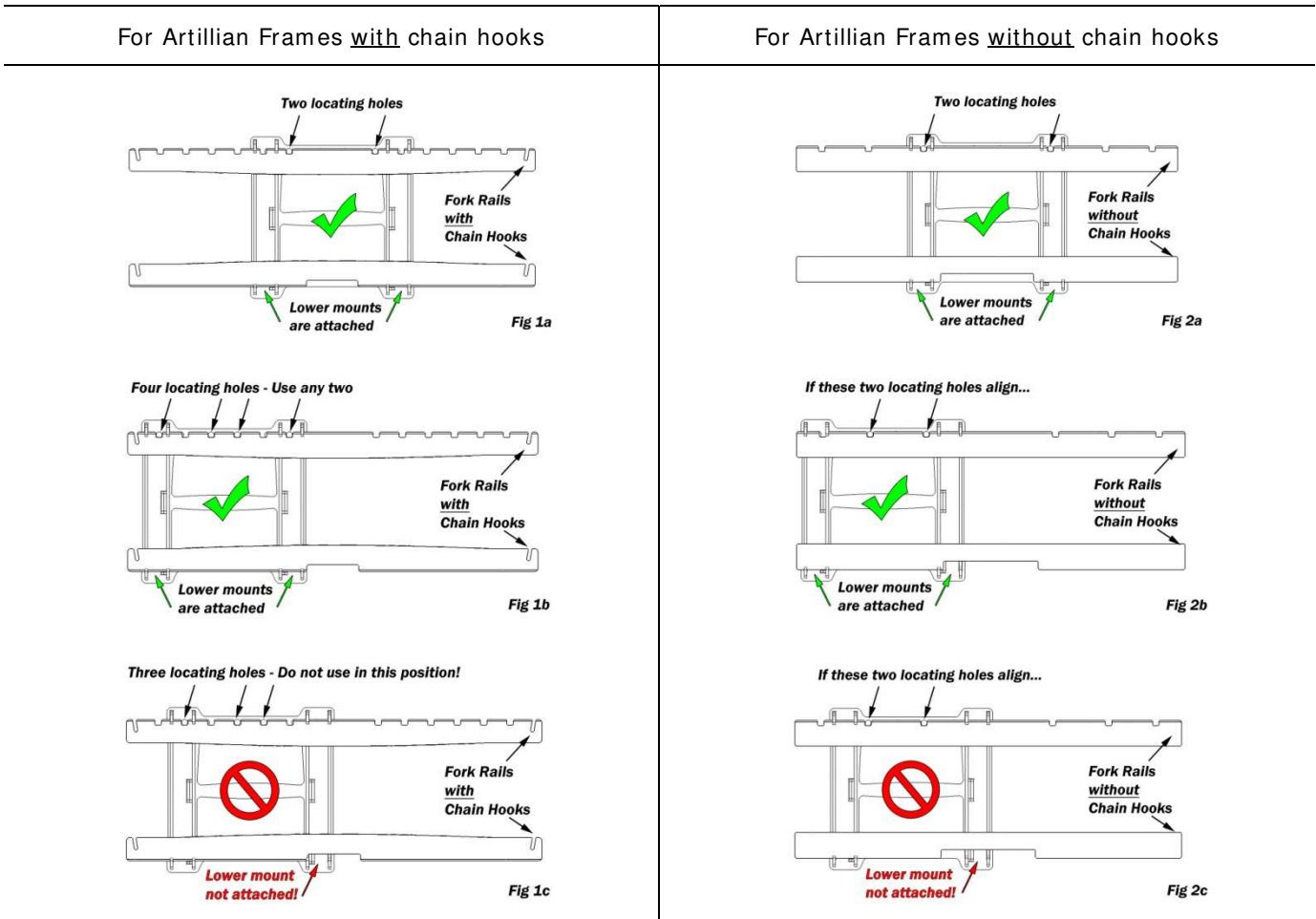

Thank you for choosing Artillian!